

# Arresters

Station Class and Intermediate

Protect Your Power.



# Warranty

## Warranty – Material

HPS warrants to Buyer that the products sold will be free of defects in workmanship or material for a period of one (1) year (or as otherwise specified) from the date of original shipment by HPS when stored, installed, operated or maintained in accordance with recommendations of HPS and standard industry practice and when used under proper and normal use. HPS shall in no event be responsible or liable for modifications, alterations, misapplication or repairs made to its products by Buyer or others, or for damage caused thereto by negligence, accident or improper use by Buyer or others. This warranty does not include reimbursement for the expenses of labor, transportation, removal or reinstallation of the products. This warranty shall run only to the first Buyer of a product from HPS, from HPS' Buyer, or from an original equipment manufacturer reselling HPS' product, and is non-assignable and non-transferable and shall be of no force and effect if asserted by any person other than such first Buyer. THE FOREGOING WARRANTY IS EXCLUSIVE AND IN LIEU OF ALL OTHER WARRANTIES WHETHER WRITTEN, ORAL, EXPRESSED OR IMPLIED. THERE ARE NO WARRANTIES OF MERCHANTABILITY OR FITNESS OF ANY PRODUCT FOR A PARTICULAR PURPOSE.

## Warranty – Application

HPS does not warrant the accuracy of and results from product or system performance recommendations resulting from any engineering analysis or study. This applies regardless of whether a charge is made for the recommendation, or if it is provided free of charge. Responsibility for selection of the proper product of application rests solely with the Buyer. In the event of errors or inaccuracies determined to be caused by HPS, its liability will be limited to the re- performance of any such analysis or study.

## BUYER INSPECTIONS

Tests, inspections and acceptance of all material must be made at the factory. Buyer's inspectors are welcome at the factories and are provided with the necessary facilities for carrying out their work. Name and phone number of who should be contacted for inspection should be given to HPS no later than two weeks prior to scheduled shipment date.

## LIMITATION OF LIABILITY

IN NO EVENT AND UNDER NO CIRCUMSTANCES SHALL HPS BE LIABLE TO BUYER OR TO ANY OTHER PERSON FOR ANY INDIRECT, SPECIAL, CONSEQUENTIAL OR INCIDENTAL LOSSES OR DAMAGES, INCLUDING, WITHOUT LIMITATION, DAMAGE TO OR LOSS OF USE OF ANY PRODUCT, LOST SALES, OR PROFITS, OR DELAY OR FAILURE TO PERFORM THIS WARRANTY OBLIGATION, OR CLAIMS OF THIRD PARTIES AGAINST PURCHASER, ARISING OUT OF OR IN CONNECTION WITH THE SALE, INSTALLATION, USE OF, INABILITY TO USE, OR THE REPAIR OR REPLACEMENT OF, HPS' PRODUCTS. As stated herein, the term "person" shall include without limitation, any individual proprietorship, partnership, corporation or entity.

## EXCLUSIVE REMEDY

Any claim by Buyer that a product is defective or non-conforming shall be deemed waived by Buyer unless submitted to HPS in writing within thirty (30) days from the date Buyer discovered, or by reasonable inspection should have discovered the alleged defect or non-conformity. Any warranty claim must be brought within one year of discovery of the alleged defect or non-conformity. Upon prompt written notice by the Buyer that a product is defective or non-conforming, HPS' liability shall be limited to repairing or replacing the product, at HPS' option.

1850 Richland Avenue, East, Aiken, SC 29801

HubbellPowerSystems.com  
1.573.682.5521 o  
1.573.682.8714 f  
hpsliterature@hubbell.com

NOTE: Because Hubbell Power Systems Inc., has a policy of continuous product improvement, we reserve the right to change design and specifications without notice.

*Copyright 2016 Hubbell Power Systems Inc./Ohio Brass*





## Surge Arresters

INSIDE.....	PAGE
Overview .....	5
Arrester Selection Guidelines .....	6
<b>Products: Polymer Housed Surge Arresters</b> .....	8
PVI-LP, Intermediate Class (ESP™ Polymer).....	9
EVP, Station Class (ESP™ Polymer) .....	13
SVN, Station Class (Silicone Polymer).....	17
SVNH and SVNX, High Strength Station Class (Silicone Polymer) .....	22
<b>Porcelain Housed Surge Arresters</b> .....	26
VL, Station Class .....	28
MVN, Station Class .....	30
General Information .....	34
Accessories / Hardware .....	35
Arresters FAQs .....	40
Engineering Terminology .....	42
Routine Factory Testing .....	44
Seismic Testing.....	45

precision





## Hubbell Arresters

### More Than a Half-century of Arrester Innovation

Ohio Brass introduced its first surge arresters more than a half-century ago. Since then, Hubbell Power Systems (HPS) and the Ohio Brass brand have led the industry in innovation, reliability and service.

During this time Hubbell, through the Ohio Brass brand name, introduced the world's first polymer-housed arresters, advanced MOV disc technology and refined manufacturing processes. The company has obtained many patents for products and design features that have helped keep Hubbell arresters at the forefront of technology.



Since your customers' power is only as reliable as your delivery system, trust your lines, substations and reputation to Hubbell Power System's Ohio Brass arresters.

# engineering



# Overview

**Equipment Protection is Job One** – Next to your people, your power grid infrastructure is your largest and most valuable investment. Protect it with Hubbell Power Systems (HPS) surge arresters. Every lightning strike, insulator flashover and switching surge adds wear and tear to your equipment, prematurely aging it, and requiring you to shoulder the costs of replacement. Even the smallest surge can shorten your equipment's life. Surge arresters, however, extend the life of your system by limiting the voltage across your equipment during a surge event.

**How Arresters Work** – Arresters, when placed in substations or on transmission or distribution lines, protect connected equipment against all types of voltage surges. Appearing as a very high impedance at normal operating voltages, the arrester rapidly transitions to a very low impedance on the arrival of a high voltage surge resulting from lightning or switching activity. The arrester, typically connected from line-to-ground across the equipment to be protected, then provides a by-pass route for surge current and, at the same time, clamps the line-to-ground voltage to a level well below the insulation withstand level (BIL or BSL) of the equipment. Once the surge has passed, the arrester returns to its original state, and the system survives the event without disruption.

**Advancing Arrester Technology** – The Ohio Brass Company, now fully integrated into Hubbell Power Systems, began the manufacture of surge arresters in 1950. The company had been, and continues to be, a major manufacturer of high voltage insulators, using the knowledge and experience gained in that long history to improve and innovate the arrester product lines, first with its own production of porcelain housings, later with the development of polymer materials for high voltage insulation that are now used for the latest technology polymer-housed arresters. Separately from the insulating materials development, the company was among the very early pioneers in metal oxide varistor (MOV) technology, which is at the heart of all modern surge arresters. It is the MOV that provides the non-linear resistance characteristic that gives the arrester the voltage limiting and current by-pass characteristics mentioned above. Over the years, HPS has made great strides in MOV technology, improving energy handling capability and providing better voltage clamping, allowing us to continue providing our customers with "best of class" surge protection, accompanied by "best in class" customer service.

**Our High Quality MOV Discs and Polymer Housings** – We opened our MOV disc plant in 1977 to control the most critical components of our surge arresters. This long history with MOV technology ensures that the MOV discs used in HPS arresters will always meet our exacting standards.

Our proprietary ESP™ weathershed material, made of a silicone/EPDM alloy, resists tracking and provides exceptional leakage distance. It has proven its mettle in some of the toughest weather conditions for the past decades.

We perform extensive testing on all of our products to ensure that all of our arresters meet or exceed industry standards.

These features protect your lines, your linemen and your bottom line.



# Arrester Selection Guidelines

**Selecting the Right Arrester for Your Needs** – Selecting an appropriate arrester requires knowledge about your system and specific application. Factors that come into play are:

- Maximum system voltage
- System grounding practices (effectively grounded, impedance grounded, ungrounded)
- Insulation level of equipment to be protected
- Desired margins of protection to be provided
- Levels and durations of power frequency overvoltages
- Lengths of lines that will be switched
- Mechanical loads that arrester will be subjected to
- Available line-to-ground fault current
- Environmental conditions.

## Summary Table Comparison

Product Line	Class	Voltage Rating (kV rms)	MCOV (kV rms)	Housing Material	Energy Capability (kJ/kV-MCOV)†	Rated Short Circuit Current (Pressure Relief) (kA rms)	Maximum Working Cantilever (in-lb)	Maximum Short-Term Cantilever (in-lb)
PVI-LP	Intermediate	3 - 72	2.55 - 57	ESP™ Polymer	6	40	1,600	3,200
EVP	Station	3 - 228	2.55 - 180	ESP™ Polymer	9	63	10,000 ‡	20,000 ‡
SVN	Station	12 - 564	10.2 - 448	Silicone Polymer	11	65	35,000	70,000
VL	Station	3 - 48	2.55 - 39	Porcelain	9	65	28,000	70,000
MVN	Station	12 - 444	10.2 - 353	Porcelain	11	65	60,000	150,000
SVNH	Station	144-444	115-353	Silicone Polymer	11	65	150,000	300,000
SVNX	Station	258 - 588*	209 - 470*	Silicone Polymer	21	65	150,000	300,000

\* Higher and lower voltage units are available upon request.

† Energy imparted to the arrester over a one minute period, from which the arrester can thermally recover at MCOV under usual service conditions.

‡ For ratings above 115kV MCOV, the maximum working cantilever is 5,000 in-lb & the maximum short-term cantilever is 10,000 in-lb. Applies to arresters with a tripod mounting base.

## Normal Operating Conditions (per IEEE/ANSI Std. C62.11)

### Arrester Standard Operating Conditions

- Nominal Power Frequency Range: 48 Hz to 62 Hz
- Ambient Air Temperature: -40 °C to 40 °C
- Altitude: Up to 6,000 ft above sea level (1,800 m)
  - Hubbell arresters are suitable for operation at higher altitudes.

\* For applications outside the usual service conditions, or any other application related question, please contact your Hubbell Power Systems Representative at 1.573.682.5521.



# Arrester Selection Guidelines

## Normally Recommended Arrester MCOV for Various System Voltages

System L-L Voltage kV		Arrester MCOV (kV)		
		Grounded Neutral Circuits	Temporarily Ungrounded, Impedance Grounded or Ungrounded Circuits	
Nominal	Maximum		(1)	(2)
2.40	2.52	2.55	2.55	2.55
4.16	4.37	2.55	5.1	5.1
4.8	5.04	5.1	5.1	5.1
6.9	7.25	5.1	7.65	7.65
8.32	8.74	5.1	7.65	8.4
12.0	12.6	7.65	10.2	12.7
12.47	13.1	7.65	12.7	12.7
13.2	13.9	8.4	12.7	12.7
13.8	14.5	8.4	12.7	15.3
20.78	21.8	12.7	19.5	22.0
22.86	24.0	15.3	19.5	22.0
23.0	24.2	15.3	19.5	22.0
24.94	26.2	15.3	22.0	24.0
34.5	36.2	22.0	29.0	36.0
46.0	48.3	29.0	39.0	48.0
69.0	72.5	42.0	57.0	70.0
115.0	121.0	70.0	98.0	115.0
138.0	145.0	84.0	115.0	131.0
161.0	169.0	98.0	140.0	152.0
230.0	242.0	140.0	209.0	220.0
345.0	362.0	209.0	–	–
400.0	420.0	245.0	–	–
500.0	550.0	318.0	–	–
765.0	800.0	470.0	–	–

Notes: (1) For normal duty. Line-to-ground fault up to 30 minutes.

(2) For severe duty. Line-to-ground fault up to 2,000 hours.



trust

# Polymer Housed Surge Arresters





# Products – Polymer Housed Surge Arresters – PVI-LP

## PVI-LP, Intermediate Class

**Overview** – PVI-LP arresters are the most economical arrester to use on systems up to 69 kV (72.5 kV max). They are particularly suited for light-to-moderate duty applications where light weight and compact profile are of particular importance. Their narrow profile allows smaller phase-to-ground clearances and phase-to-phase spacings than other arresters, making them particularly well-suited for installations where space is at a premium, such as cabinets or other electrical enclosures and on mobile substations.

### Construction:

- “Wrap” design, using fiberglass reinforced epoxy stranding to form a wrapped envelope directly over the MOV discs
- ESP™ rubber housing applied over wrapped MOV module
- Silicone compound interface between module and housing to render a void-free assembly
- Tripod base (Slotted 8.75” – 10” bolt circle)

### At-a-Glance:

- Less than half the weight of a comparably rated porcelain-housed arrester
- Narrow profile for reduced clearance to ground and between phases
- Install straight from the package – no field assembly required



### Flash Fact:

*Today's MOV arresters provide much better protection than older Silicon Carbide designs.*

# Products – Polymer Housed Surge Arresters – PVI-LP

## PVI-LP Electrical Characteristics

Standard Arrester Catalog Number	Duty Cycle Rating (kV rms)	MCOV Maximum Continuous Operating Voltage (kV rms)	Maximum 0.5 $\mu$ s Discharge Voltage (kV) @ 10 kA	Maximum Switching Surge Protective Level (kV) *	TOV Capability (No Prior Duty)		Maximum Discharge Voltage using an 8/20 Current Wave (kV)					
					1 sec (kV rms)	10 sec (kV rms)	1.5kA	3kA	5kA	10kA	20kA	40kA
300803-3001	3	2.55	8.6	6.4	3.7	3.6	6.8	7.2	7.5	8.1	9.0	10.1
300805-3001	6	5.1	17.1	12.7	7.5	7.1	13.6	14.4	15.0	16.2	17.9	20.2
300808-3001	9	7.65	25.8	19.1	11.2	10.7	20.5	21.6	22.6	24.4	27.0	30.4
300809-3001	10	8.4	28.4	21.1	12.3	11.7	22.6	23.8	24.9	26.9	29.8	33.5
300610-3001	12	10.2	34.1	25.3	14.9	14.2	27.1	28.6	29.9	32.3	35.8	40.3
300813-3001	15	12.7	42.9	31.8	18.6	17.7	34.1	36.0	37.6	40.6	44.9	50.6
300815-3001	18	15.3	51.6	38.3	22.4	21.3	40.9	43.2	45.2	48.8	54.0	60.9
300817-3001	21	17	56.9	42.2	24.9	23.7	45.1	47.7	49.9	53.8	59.6	67.1
300620-3001	24	19.5	68.3	50.6	28.6	27.2	54.2	57.2	59.9	64.6	71.5	80.6
300822-3001	27	22	77.4	57.4	32.2	30.7	61.4	64.9	67.9	73.2	81.0	91.3
300824-3001	30	24.4	85.3	63.3	35.7	34.0	67.7	71.5	74.8	80.7	89.3	101.0
300629-3001	36	29	102.0	76.0	42.5	40.5	81.3	85.9	89.8	96.9	107.0	121.0
300831-3001	39	31.5	108.0	80.4	46.1	43.9	86.1	90.9	95.1	103.0	114.0	128.0
300636-3001	45	36.5	125.0	92.8	53.5	50.9	99.3	105.0	110.0	118.0	131.0	148.0
300639-3001	48	39	137.0	101.0	57.1	54.4	108.0	115.0	120.0	129.0	143.0	161.0
300642-3001	54	42	148.0	110.0	61.5	58.6	117.0	125.0	130.0	140.0	155.0	175.0
300648-3001	60	48	165.0	122.0	70.3	67.0	131.0	138.0	145.0	156.0	173.0	195.0
300657-3001	72	57	199.0	148.0	83.5	79.5	158.0	167.0	175.0	188.0	209.0	235.0

\* 500A surge of 45  $\mu$ s time to crest.

### Flash Fact:

*The most common duty on substation arresters comes from system switching events not lightning.*



# Products – Polymer Housed Surge Arresters – PVI-LP

## PVI-LP Physical Characteristics

Standard Arrester Catalog Number	Duty Cycle Rating (kV rms)	MCOV Maximum Continuous Operating Voltage (kV rms)	Height Dimension (Inches)	Leakage Distance (Inches)	Recommended Minimum Clearance (Inches)		Net Weight (Pounds)
					Ph - Ph	Ph - Gd	
300803-3001	3	2.55	6.8	15.4	4.4	3.3	6
300805-3001	6	5.1	6.8	15.4	4.6	3.2	6
300808-3001	9	7.65	6.8	15.4	4.7	3.3	6
300809-3001	10	8.4	6.8	15.4	4.9	3.5	6
300610-3001	12	10.2	6.8	15.4	4.9	3.5	6
300813-3001	15	12.7	12.2	30.8	6.2	4.8	10
300815-3001	18	15.3	12.2	30.8	6.6	5.2	10
300817-3001	21	17	12.2	30.8	7.6	6.2	10
300620-3001	24	19.5	12.2	30.8	7.6	6.2	10
300822-3001	27	22	17.6	46.2	9.6	8.2	14
300824-3001	30	24.4	17.6	46.2	9.8	8.4	14
300629-3001	36	29	17.6	46.2	9.8	8.4	14
300831-3001	39	31.5	23.0	61.6	12.8	11.4	17
300636-3001	45	36.5	23.0	61.6	12.8	11.4	17
300639-3001	48	39	23.0	61.6	12.8	11.4	17
300642-3001	54	42	28.4	77.0	15.8	14.4	20
300648-3001	60	48	28.4	77.0	15.8	14.4	20
300657-3001	72	57	33.8	92.4	19.8	18.4	23

**Figure 1**

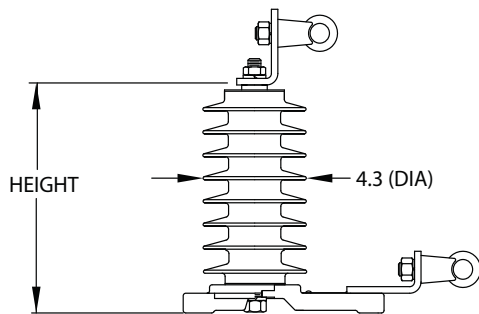

**Base Mounting Information**

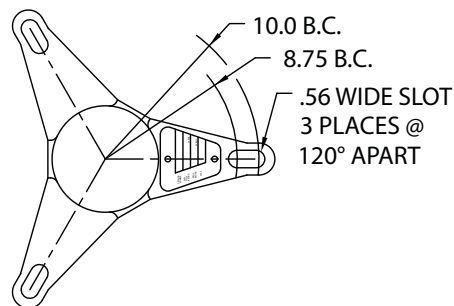



# Products – Polymer Housed Surge Arresters – PVI-LP

## PVI-LP Part Number Selection

30 X YYY - 3001

### Step 1: Configuration

### Step 2: Catalog Key

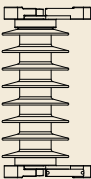
X->	0 (standard)	1	2 (underhung)	3
Top	Cap	Cap	Tripod	Tripod
Bottom	Tripod	Cap	Cap	Tripod
				

MCOV Rating (kV)	YYY	MCOV Rating (kV)	YYY
2.55	803	22	822
5.1	805	24.4	824
7.65	808	29	629
8.4	809	31.5	831
10.2	610	36.5	636
12.7	813	39	639
15.3	815	42	642
17	817	48	648
19.5	620	57	657

### Step 3: Hardware

- **3001:**

**Top:** Single Eye Bolt  
**Bottom:** Single Eye Bolt

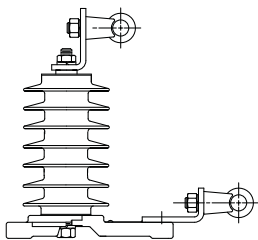

- **3002:**

**Top:** 4-Hole NEMA pad with (2) Single Eye Bolts  
**Bottom:** Single Eye Bolt

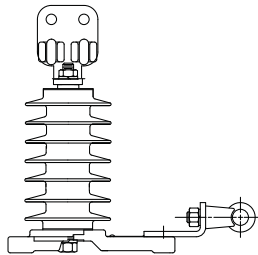

- **3011:**

**Crossarm Mount** (for use with 301YYY) codes only

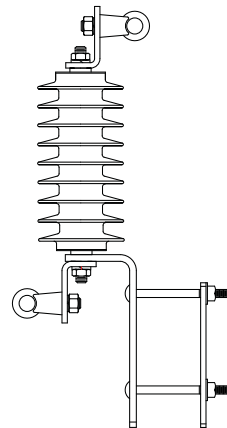

\* For additional hardware options or non-standard configurations, please contact your Hubbell Power Systems Representative at 1.573.682.5521.

\* See page 36 for hardware details.



# Products – Polymer Housed Surge Arresters – EVP

## EVP, Station Class

**Overview** – The EVP Polymer Housed Station Arrester by HPS and Ohio Brass represents the absolute latest in surge arrester technology. Based on proven PVN technology, our EVP line maintains our proprietary ESP™ weathershed material and protective levels. However, it has an even more robust sealing system to reduce moisture ingress to an unprecedented minimum. EVP arresters also feature a redesigned housing profile for maximum material utilization, and even make ordering easier by using an intelligent numbering system.

### Construction:

- Optimized wrap pattern and end hardware
- Even more effective sealing system
- Aluminum Top Cap
- Tri-pod base (standard 8.75" to 10" BC) Slotted

### At-a-Glance:

- The latest in surge arrester technology
- Utilizes proprietary ESP™ weathershed material
- More robust sealing system reduces moisture ingress

### Our EVP Arresters Feature:

- 25% Recycled Packaging Material
- 15% Less Production Mass Compared to Previous Designs
- 50% Recyclable Packaging

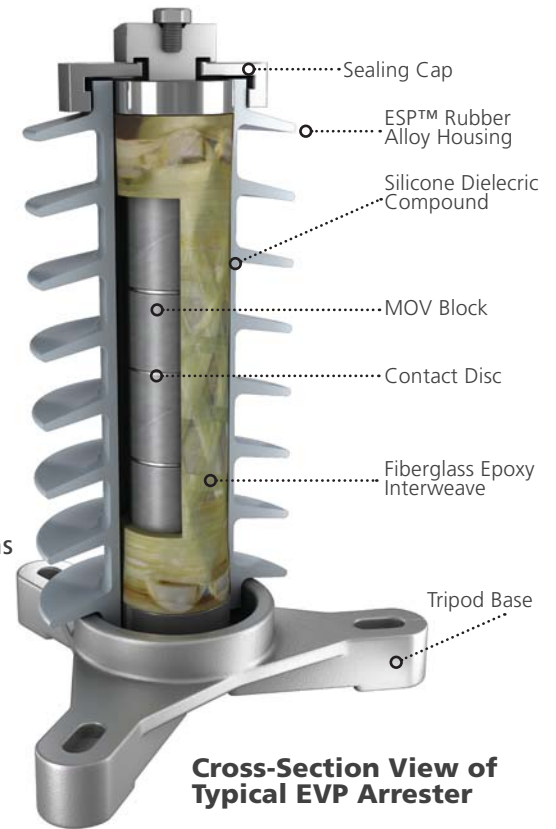

**Cross-Section View of Typical EVP Arrester**

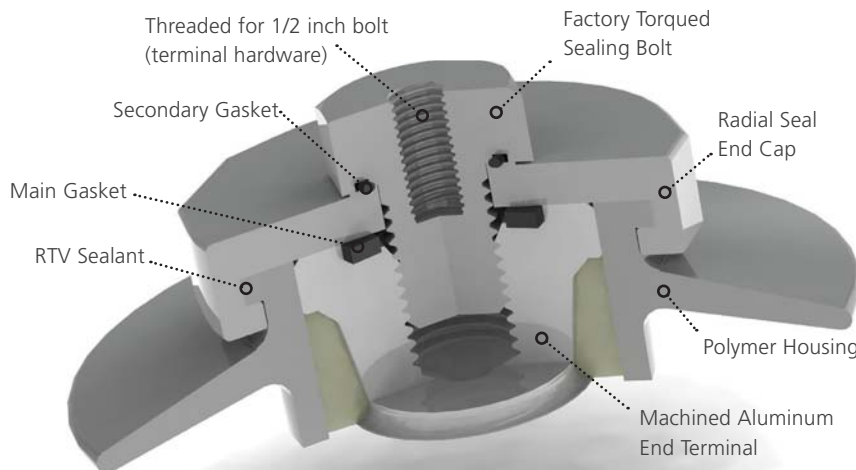

**Detailed View of Sealing**

# Products – Polymer Housed Surge Arresters – EVP

## EVP Electrical Characteristics

Standard Arrester Catalog Number	Duty Cycle Rating (kV rms)	MCOV Maximum Continuous Operating Voltage (kV rms)	Maximum 0.5 $\mu$ s Discharge Voltage (kV) @ 10 kA	Maximum Switching Surge Protective Level (kV) *	TOV Capability (No Prior Duty)		Maximum Discharge Voltage using an 8/20 Current Wave (kV)					
					1 sec (kV rms)	10 sec (kV rms)	1.5kA	3kA	5kA	10kA	20kA	40kA
EVP000300	3	2.55	10.5	6.0	3.6	3.5	6.4	6.7	7.1	7.6	8.2	9.3
EVP000500	6	5.1	18.6	12.0	7.3	6.9	12.8	13.5	14.1	15.2	16.4	18.7
EVP000800	9	7.65	27.0	18.0	10.9	10.4	19.2	20.2	21.2	22.7	24.6	28.0
EVP000900	10	8.4	29.4	19.8	11.9	11.4	21.1	22.2	23.3	25.0	27.0	30.8
EVP001000	12	10.2	35.1	24.0	14.5	13.9	25.6	26.9	28.2	30.3	32.8	37.4
EVP001300	15	12.7	43.4	29.9	18.0	17.3	31.9	33.5	35.2	37.7	40.8	46.5
EVP001500	18	15.3	51.6	36.1	21.7	20.8	38.5	40.4	42.4	45.5	49.1	56.1
EVP001700	21	17	57.8	40.1	24.2	23.1	42.7	44.9	47.1	50.5	54.6	62.3
EVP001900	24	19.5	65.7	45.9	27.7	26.5	49.0	51.5	54.0	57.9	62.6	71.4
EVP002200	27	22	73.6	51.8	31.3	29.9	55.3	58.1	60.9	65.4	70.7	80.6
EVP002400	30	24.4	81.2	57.5	34.7	33.2	61.3	64.5	67.6	72.5	78.4	89.4
EVP002900	36	29	97.0	68.6	41.4	39.6	73.2	76.9	80.7	86.5	93.6	107.0
EVP003100	39	31.5	105.0	74.4	44.8	42.9	79.3	83.4	87.4	93.8	101.0	116.0
EVP003600	45	36.5	121.0	86.0	51.9	49.6	91.8	96.4	101.0	108.0	117.0	134.0
EVP003900	48	39	129.0	91.9	55.4	53.0	98.0	103.0	108.0	116.0	125.0	143.0
EVP004200	54	42	145.0	104.0	62.5	59.8	111.0	116.0	122.0	131.0	141.0	161.0
EVP004800	60	48	160.0	115.0	69.0	66.0	123.0	129.0	135.0	145.0	157.0	179.0
EVP005700	72	57	192.0	137.0	82.8	79.3	147.0	154.0	161.0	173.0	187.0	214.0
EVP007000	90	70	242.0	172.0	104.0	99.3	184.0	193.0	202.0	217.0	234.0	267.0
EVP007400	90	74	245.0	174.0	105.0	101.0	186.0	195.0	205.0	220.0	238.0	271.0
EVP007600	96	76	257.0	184.0	111.0	106.0	196.0	206.0	216.0	232.0	251.0	286.0
EVP008400	108	84	289.0	207.0	125.0	120.0	221.0	232.0	244.0	261.0	283.0	322.0
EVP008800	108	88	289.0	207.0	125.0	120.0	221.0	232.0	244.0	261.0	283.0	322.0
EVP009800	120	98	322.0	241.0	139.0	133.0	246.0	259.0	271.0	291.0	315.0	359.0
EVP010600	132	106	350.0	262.0	152.0	145.0	268.0	282.0	296.0	317.0	343.0	391.0
EVP011500	144	115	382.0	286.0	166.0	159.0	293.0	308.0	323.0	346.0	375.0	427.0
EVP013100	168	131	447.0	334.0	194.0	185.0	342.0	360.0	377.0	405.0	438.0	499.0
EVP014000	172	140	462.0	344.0	199.0	191.0	352.0	370.0	388.0	416.0	450.0	513.0
EVP014400	180	144	480.0	357.0	207.0	198.0	366.0	385.0	403.0	433.0	468.0	534.0
EVP015200	192	152	510.0	381.0	221.0	211.0	391.0	411.0	430.0	462.0	499.0	569.0
EVP018000	228	180	605.0	453.0	262.0	251.0	464.0	487.0	511.0	548.0	593.0	676.0

\* Discharge voltages are based on a 500A surge of 45  $\mu$ s time to crest through 88 kV MCOV and 1,000A surge of 45  $\mu$ s time through 180 kV MCOV.



# Products – Polymer Housed Surge Arresters – EVP

## EVP Physical Characteristics

Standard Arrester Catalog Number	Duty Cycle Rating (kV rms)	MCOV Maximum Continuous Operating Voltage (kV rms)	Height Dimension (Inches)	Leakage Distance (Inches)	Recommended Minimum Clearance (Inches)		Net Weight (Pounds)
					Ph - Ph	Ph - Gd	
EVP000300	3.0	2.55	9.9	19.6	9.0	4.5	13
EVP000500	6.0	5.1	9.9	19.6	9.0	4.5	13
EVP000800	9.0	7.65	11.7	30.1	9.0	4.5	15
EVP000900	10.0	8.4	11.7	30.1	9.0	4.5	15
EVP001000	12.0	10.2	11.7	30.1	9.0	4.6	15
EVP001300	15.0	12.7	13.5	35.4	9.7	5.4	17
EVP001500	18.0	15.3	13.5	35.4	10.6	6.1	17
EVP001700	21.0	17	17.2	40.5	11.2	6.7	22
EVP001900	24.0	19.5	17.2	40.5	12.1	7.4	22
EVP002200	27.0	22	17.2	40.5	12.9	8.2	22
EVP002400	30.0	24.4	17.2	40.5	13.8	8.9	22
EVP002900	36.0	29	20.9	50.9	15.4	10.3	27
EVP003100	39.0	31.5	20.9	50.9	16.2	11.1	27
EVP003600	45.0	36.5	24.5	61.5	17.9	12.6	31
EVP003900	48.0	39	24.5	61.5	18.8	13.3	31
EVP004200	54.0	42	24.5	61.5	20.5	14.9	31
EVP004800	60.0	48	28.2	71.9	22.1	16.2	36
EVP005700	72.0	57	31.9	82.4	25.4	19.2	41
EVP007000	90.0	70	46.3	123.0	30.5	23.7	59
EVP007400	90.0	74	46.3	123.0	30.8	24.0	59
EVP007600	96.0	76	46.3	123.0	32.2	25.2	59
EVP008400	108.0	84	46.3	123.0	35.6	28.2	59
EVP008800	108.0	88	46.3	123.0	35.6	28.2	59
EVP009800	120.0	98	53.7	143.9	48.6	36.0	73
EVP010600	132.0	106	53.7	143.9	51.6	38.7	73
EVP011500	144.0	115	61.0	164.8	55.0	41.7	82
EVP013100	168.0	131	72.5	184.5	61.7	47.7	97
EVP014000	172.0	140	83.5	215.8	74.4	60.5	120
EVP014400	180.0	144	83.5	215.8	76.3	62.4	120
EVP015200	192.0	152	83.5	215.8	79.7	65.8	120
EVP018000	228.0	180	94.5	247.2	89.7	75.7	133

Figure 1

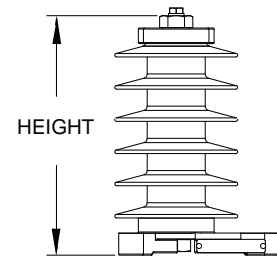
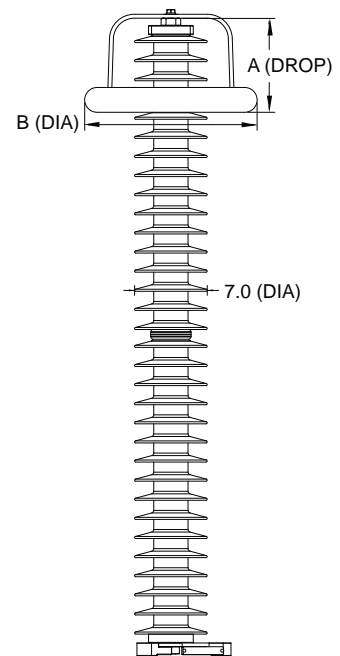
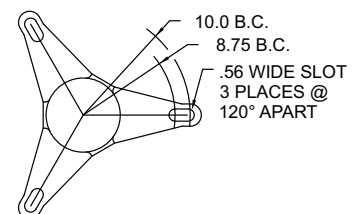

Figure 2



## Base Mounting Information



## Grading Ring Diameters

Arrester MCOV	Drop (A) (inches)	Diameter (B) (inches)
98.0 - 131.0	9.0	16.5
140.0 - 180.0	14.5	27.9

# Products – Polymer Housed Surge Arresters – EVP

## EVP Part Number Selection

EVP X YYY 0 0 - 3001

### Step 1: Configuration

X->	0 (standard)	1	2 (underhung)	3	9 (Multi Rated)
Top	Cap	Cap	Tripod	Tripod	Cap
Bottom	Tripod	Cap	Cap	Tripod	Tripod

### Step 2: EVP Part Number Table

MCOV	YYY	MCOV	YYY
2.55	003	48	048
5.1	005	57	057
7.65	008	70	070
8.4	009	74	074
10.2	010	76	076
12.7	013	84	084
15.3	015	88	088
17	017	98	098
19.5	019	106	106
22	022	115	115
24.4	024	131	131
29	029	140	140
31.5	031	144	144
36.5	036	152	152
39	039	180	180
42	042		

### Step 3: Housing Leakage Distance

- 0 – Standard Leakage Distance
- 1 - High Leakage Distance
- 2 - Extra High Leakage Distance

MCOV													Height (in)	Creep (in)	
003 005	008 010	013 015	017 024	029 031	036 042	048	057	070 088	098 106	115	131	140 152			180
0	-	-	-	-	-	-	-	-	-	-	-	-	-	9.9	19.6
1	0	-	-	-	-	-	-	-	-	-	-	-	-	11.7	30.1
2	1	0	-	-	-	-	-	-	-	-	-	-	-	13.5	35.4
-	2	1	0	-	-	-	-	-	-	-	-	-	-	17.2	40.5
-	-	2	1	0	-	-	-	-	-	-	-	-	-	20.9	50.9
-	-	-	2	1	0	-	-	-	-	-	-	-	-	24.5	61.5
-	-	-	-	2	1	0	-	-	-	-	-	-	-	28.2	71.9
-	-	-	-	-	2	1	0	-	-	-	-	-	-	31.9	82.4
-	-	-	-	-	-	2	1	0	-	-	-	-	-	46.3	123.0
-	-	-	-	-	-	-	2	1	0	-	-	-	-	53.7	144.0
-	-	-	-	-	-	-	-	2	1	0	-	-	-	61.0	165.0
-	-	-	-	-	-	-	-	-	2	1	0	-	-	72.5	184.0
-	-	-	-	-	-	-	-	-	-	2	1	0	-	83.5	216.0
-	-	-	-	-	-	-	-	-	-	-	2	1	0	94.5	247.0
-	-	-	-	-	-	-	-	-	-	-	-	2	1	111.1	288.0
-	-	-	-	-	-	-	-	-	-	-	-	-	2	127.7	330.0

### Step 4: Hardware

For EVP0 & EVP2, standard housing configurations (upright & underhung):

- 3001  
Line: 4-Hole NEMA pad with (2) Single Eye Bolts

Ground: Single Eye Bolt

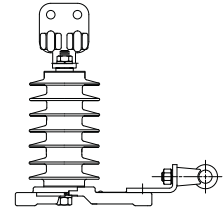

- 3002  
Line: Single Eye Bolt

Ground: Single Eye Bolt

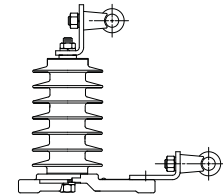

\* See page 36 for hardware details

For Hubbell internal use only (0-Standard)

\* For applications that require leakage distance, height or terminal size requirements not listed, please contact your Hubbell Power Systems Representative at 1.573.682.5521.





# Products – Polymer Housed Surge Arresters – SVN

## SVN, Station Class

**Overview** – Standard SVN station class arresters are available for use on system voltages from 22.86 kV to 500 kV (24 kV max to 550 kV max). They offer an attractive alternative to porcelain housed arresters (MVN family), without sacrificing any reduction in protective capability or energy handling capability, for cases where the high mechanical strength of porcelain is not required and lower weight would be an advantage.

### Construction:

- “Tube” design, using fiberglass reinforced epoxy tube overmolded with silicone rubber weathershed housing
- Single column of MOV discs and aluminum spacers (as required) centrally located within housing
- Disc column held under high spring compression between ductile iron end fittings affixed to housing
- Directional pressure relief system built integrated into end fittings

### At-a-Glance:

- High leakage distance designs (standard designs at least 28% more leakage distance than IEEE C62.11 minimum); higher leakage distance designs available for high pollution areas
- Up to 47% lighter than comparable porcelain arresters
- Resilient polymer housing resistant to mechanical damage
- Tested to 65kA rated short circuit current; can handle reclosures with no concern for housing fragmentation

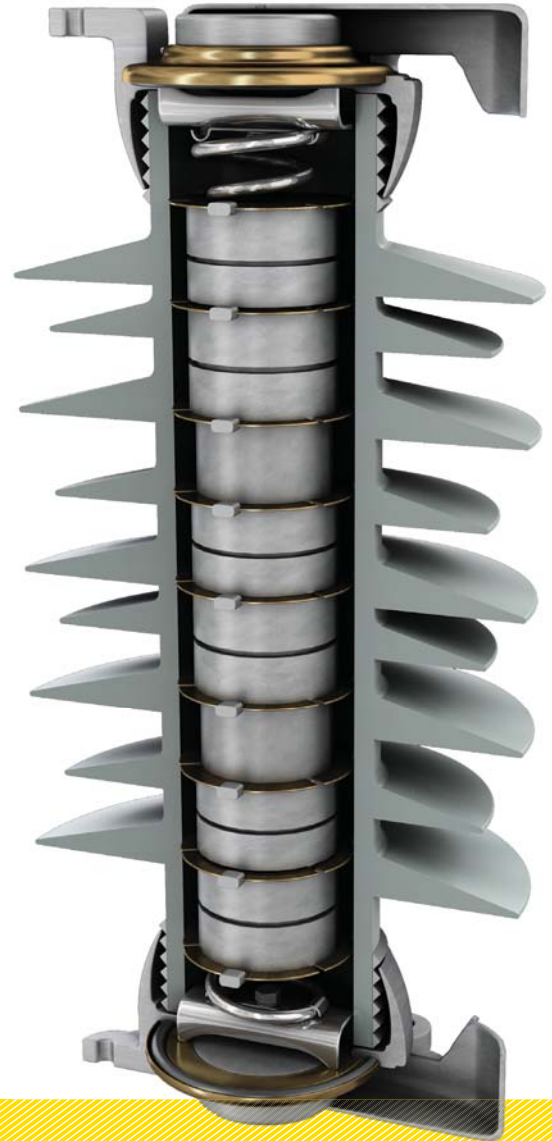

### Flash Fact:

*Surge arresters can be used to protect any type of equipment in the substation.*

# Products – Polymer Housed Surge Arresters – SVN

## SVN Electrical Characteristics

Standard Arrester Catalog Number	Duty Cycle Rating (kV rms)	MCOV Maximum Continuous Operating Voltage (kV rms)	Maximum 0.5 $\mu$ s Discharge Voltage (kV) @ 10 kA	Maximum Switching Surge Protective Level (kV) *	TOV Capability (No Prior Duty)		Maximum Discharge Voltage using an 8/20 Current Wave (kV)					
					1 sec (kV rms)	10 sec (kV rms)	1.5kA	3kA	5kA	10kA	20kA	40kA
SVN012GA010AA	12	10.2	32.1	24.4	14.9	14.3	26.2	27.3	28.2	29.6	31.6	34.8
SVN015GA013AA	15	12.7	39.9	30.3	18.5	17.8	32.6	33.9	35.1	36.8	39.3	43.3
SVN018GA015AA	18	15.3	48.2	36.5	22.3	21.4	39.3	40.9	42.3	44.4	47.4	52.5
SVN021GA017AA	21	17	53.5	40.6	24.8	23.8	43.7	45.4	47.0	49.3	53.0	58.0
SVN024GA019AA	24	19.5	62.0	46.9	28.4	27.3	50.5	52.5	54.5	57.0	61.0	67.0
SVN027GA022AA	27	22	69.5	53.0	32.1	30.8	57.0	59.0	61.0	64.0	68.5	75.5
SVN030GA024AA	30	24.4	79.0	60.0	35.6	34.1	64.5	67.0	69.5	72.5	77.5	85.5
SVN036GA029AA	36	29	92.0	69.5	42.3	40.5	75.0	78.0	80.5	84.5	90.5	99.5
SVN039GA031AA	39	31.5	101.0	76.5	45.9	44.0	82.5	86.0	89.0	93.0	99.5	110.0
SVN045GA036AA	45	36.5	115.0	87.5	53.0	51.0	94.0	98.0	101.0	106.0	114.0	125.0
SVN048GA039AA	48	39	124.0	94.0	57.0	54.5	101.0	105.0	109.0	114.0	122.0	134.0
SVN054GA042AA	54	42	133.0	101.0	61.0	58.5	108.0	113.0	117.0	122.0	131.0	144.0
SVN060GA048AA	60	48	152.0	116.0	70.0	67.0	124.0	129.0	134.0	140.0	150.0	165.0
SVN072GA057AA	72	57	180.0	137.0	83.0	79.5	147.0	153.0	159.0	166.0	178.0	195.0
SVN090GA070AA	90	70	221.0	167.0	102.0	98.0	180.0	187.0	194.0	203.0	217.0	239.0
SVN090GA074AA	90	74	234.0	177.0	108.0	103.0	191.0	198.0	205.0	215.0	230.0	253.0
SVN096GA076AA	96	76	240.0	182.0	111.0	106.0	196.0	204.0	211.0	221.0	236.0	260.0
SVN108GA084AA	108	84	265.0	201.0	122.0	117.0	216.0	225.0	233.0	244.0	261.0	287.0
SVN108GA088AA	108	88	277.0	210.0	128.0	123.0	226.0	235.0	243.0	255.0	273.0	300.0
SVN120GA098AA	120	98	308.0	241.0	143.0	137.0	252.0	262.0	271.0	284.0	304.0	334.0
SVN132GA106AA	132	106	334.0	261.0	155.0	148.0	273.0	284.0	294.0	308.0	329.0	362.0
SVN144GA115AA	144	115	363.0	283.0	168.0	161.0	296.0	308.0	318.0	334.0	357.0	393.0
SVN168GA131AA	168	131	412.0	322.0	191.0	183.0	337.0	350.0	362.0	380.0	406.0	447.0
SVN172GA140AA	172	140	441.0	344.0	204.0	196.0	360.0	374.0	387.0	406.0	434.0	477.0
SVN180GA144AA	180	144	454.0	355.0	210.0	201.0	370.0	385.0	398.0	418.0	447.0	491.0
SVN192GA152AA	192	152	479.0	374.0	222.0	212.0	391.0	406.0	420.0	441.0	471.0	518.0
SVN198GA158AA	198	158	497.0	388.0	230.0	221.0	406.0	422.0	437.0	458.0	489.0	538.0
SVN202GA161AA	202	161	507.0	396.0	235.0	225.0	414.0	430.0	445.0	467.0	499.0	549.0
SVN218GA175AA	218	175	551.0	431.0	255.0	245.0	450.0	468.0	484.0	508.0	543.0	597.0
SVN228GA180AA	228	180	566.0	443.0	262.0	252.0	462.0	481.0	497.0	522.0	557.0	613.0
SVN240GA190AA	240	190	598.0	467.0	277.0	266.0	488.0	507.0	525.0	551.0	588.0	647.0
SVN258GA209AA	258	209	657.0	532.0	305.0	292.0	537.0	558.0	577.0	606.0	647.0	712.0
SVN264GA212AA	264	212	667.0	540.0	309.0	296.0	545.0	566.0	586.0	615.0	657.0	723.0
SVN276GA220AA	276	220	692.0	560.0	321.0	308.0	565.0	587.0	608.0	638.0	681.0	750.0
SVN288GA230AA	288	230	724.0	585.0	335.0	322.0	591.0	614.0	635.0	667.0	712.0	784.0
SVN312GA245AA	312	245	770.0	623.0	357.0	343.0	629.0	654.0	676.0	710.0	758.0	834.0
SVN396GA318AA	396	318	1053.0	809.0	464.0	445.0	816.0	849.0	878.0	922.0	984.0	1083.0
SVN420GA335AA	420	335	1109.0	852.0	488.0	468.0	860.0	894.0	925.0	971.0	1037.0	1140.0
SVN444GA353AA	444	353	1169.0	898.0	515.0	493.0	906.0	942.0	974.0	1023.0	1092.0	1202.0
SVN564GA448AA	564	448	1484.0	1140.0	653.0	626.0	1150.0	1196.0	1237.0	1299.0	1387.0	1526.0

\* Discharge voltages are based on a 500A surge of 45  $\mu$ s time to crest through 88 kV MCOV and 1,000A surge of 45  $\mu$ s time through 190 kV MCOV and 2,000A through 448 kV MCOV.



# Products – Polymer Housed Surge Arresters – SVN

## SVN Physical Characteristics

Standard Arrester Catalog Number	Duty Cycle Rating (kV rms)	MCOV Continuous Operating Voltage (kV rms)	Height Dimension (Inches)	Leakage Distance (Inches)	Drawing Figure	Recommended Minimum Clearance (Inches)		Net Weight (Pounds)
						Ph – Gd	Ph – Ph	
SVN012GA010AA	12	10.2	38.1	83.9	1	1.4	0.8	104
SVN015GA013AA	15	12.7	38.1	83.9	1	2.1	1.4	106
SVN018GA015AA	18	15.3	38.1	83.9	1	2.8	2.0	107
SVN021GA017AA	21	17	38.1	83.9	1	3.3	2.4	107
SVN024GA019AA	24	19.5	38.1	83.9	1	4.0	3.0	109
SVN027GA022AA	27	22	38.1	83.9	1	4.6	3.6	111
SVN030GA024AA	30	24.4	38.1	83.9	1	5.4	4.3	112
SVN036GA029AA	36	29	38.1	83.9	1	6.5	5.3	115
SVN039GA031AA	39	31.5	38.1	83.9	1	7.3	5.9	116
SVN045GA036AA	45	36.5	38.1	83.9	1	8.5	7.0	119
SVN048GA039AA	48	39	38.1	83.9	1	9.2	7.6	120
SVN054GA042AA	54	42	38.1	83.9	1	9.9	8.3	122
SVN060GA048AA	60	48	38.1	83.9	1	11.6	9.8	125
SVN072GA057AA	72	57	38.1	83.9	1	14.0	11.9	130
SVN090GA070AA	90	70	44.4	113.4	1	17.3	14.8	144
SVN090GA074AA	90	74	44.4	113.4	1	18.4	15.8	145
SVN096GA076AA	96	76	44.4	113.4	1	18.9	16.3	146
SVN108GA084AA	108	84	52.1	142.5	1	21.1	18.1	160
SVN108GA088AA	108	88	52.1	142.5	1	22.1	19.1	161
SVN120GA098AA	120	98	52.1	142.5	1	24.7	21.4	168
SVN132GA106AA	132	106	58.8	172.0	1	26.9	23.3	181
SVN144GA115AA	144	115	58.8	172.0	1	29.3	25.4	186
SVN168GA131AA	168	131	76.8	197.2	2	33.5	29.1	264
SVN172GA140AA	172	140	76.8	197.2	3	35.8	31.2	286
SVN180GA144AA	180	144	76.8	197.2	3	37.0	32.2	288
SVN192GA152AA	192	152	83.1	226.8	3	39.0	34.0	298
SVN198GA158AA	198	158	83.1	226.8	3	40.5	35.4	302
SVN202GA161AA	202	161	83.1	226.8	3	41.4	36.1	304
SVN218GA175AA	218	175	90.8	255.9	3	45.2	39.5	320
SVN228GA180AA	228	180	90.8	255.9	3	46.4	40.5	324
SVN240GA190AA	240	190	98.5	285.0	3	49.0	42.9	338
SVN258GA209AA	258	209	105.2	314.6	3	54.1	47.3	365
SVN264GA212AA	264	212	105.2	314.6	3	54.9	48.1	367
SVN276GA220AA	276	220	105.2	314.6	3	57.0	49.9	371
SVN288GA230AA	288	230	111.9	344.1	3	59.6	52.3	387
SVN312GA245AA	312	245	129.6	369.3	4	63.5	55.7	459
SVN396GA318AA	396	318	151.7	457.1	4	82.9	72.8	559
SVN420GA335AA	420	335	158.4	486.6	4	87.4	76.8	578
SVN444GA353AA	444	353	165.1	516.1	4	92.1	81.0	597
SVN564GA448AA	564	448	211.5	658.7	5	117.3	103.3	751

# Products – Polymer Housed Surge Arresters – SVN

## Grading Ring Diameters

Arrester MCOV	Drop (A) (inches)	Diameter (B) (inches)
140–190	15.0	25.0
209–245	18.0	39.0
318–448	35.8	60.0

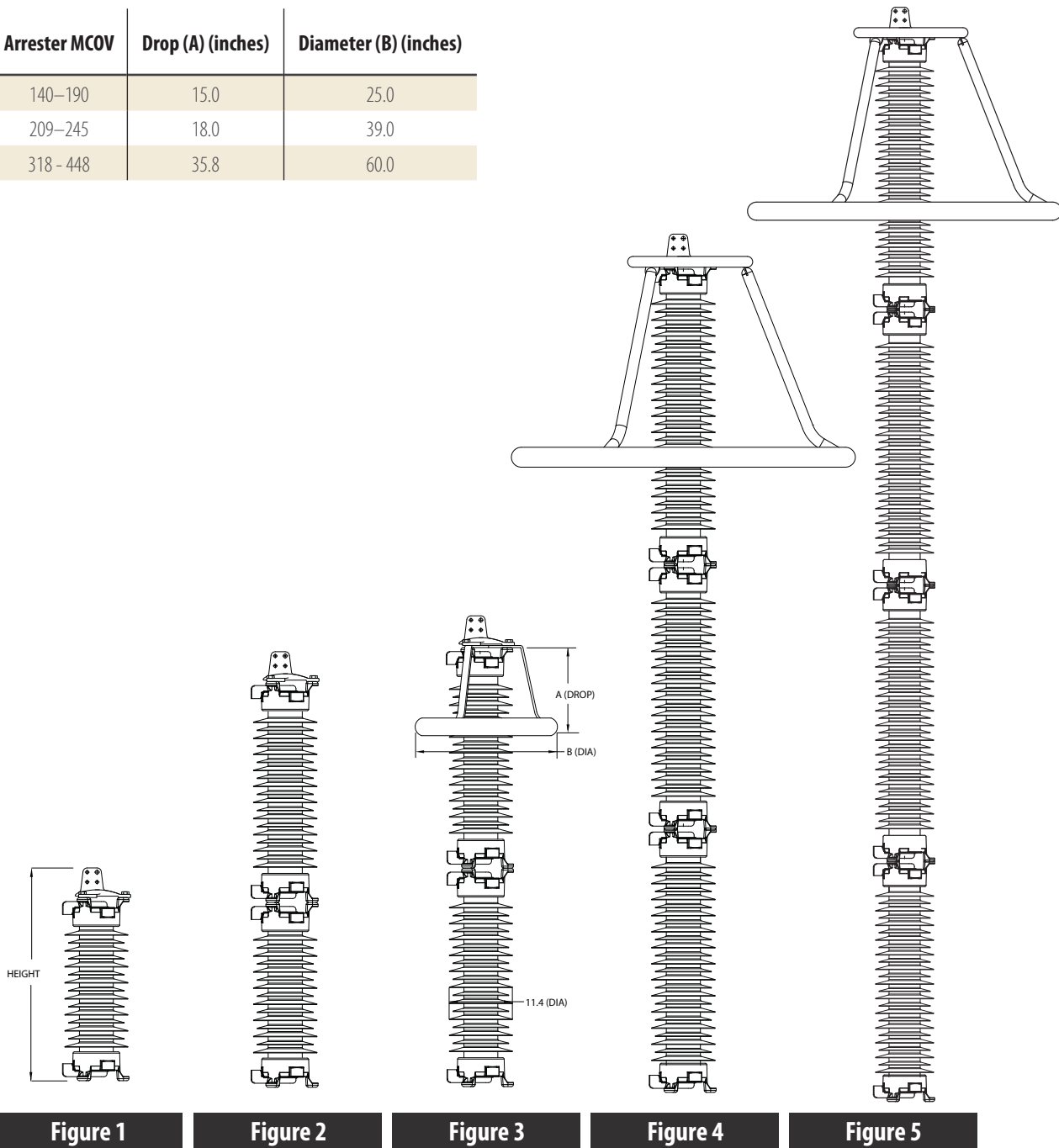

Figure 1

Figure 2

Figure 3

Figure 4

Figure 5

# Products – Polymer Housed Surge Arresters – SVN

## SVN Part Numbers

S V N 0 5 4 G A 0 4 2 A A

### Step 1: Select Standard Part Number

Use Column 1 of Page 18 to select a standard part number, including Duty Cycle and MCOV ratings.

### Duty Cycle Rating

### Step 2: Configurations

G – Standard  
U – Underhung

### Step 3: Leakage Distance Requirement

A - Standard Leakage Distance  
B - High Leakage Distance  
C - Extra High Leakage Distance  
D - Mega High Leakage Distance

### MCOV Rating

### Step 4: Line Terminals

A – Standard

Line Size (in)	Code
0.25 – 0.81	A
0.38 – 1.12	B

### Step 5: Ground Terminals

A – Standard

Ground Size (in)	Code
0.25 – 0.81	A
0.38 – 1.12	B

\* See page 36 for hardware details.

Letter Code	MCOV															Height (in)	Leakage Distance (in)
	010 057	070 076	084 098	106 115	131 144	152 161	175 180	190	209 220	230	245	318	335	353	448		
A																38.1	83.9
B	A															44.4	113.4
C	B	A														52.1	142.5
D	C	B	A													58.8	172.0
	D	C	B	A												76.8	197.2
		D	C	B	A											83.1	226.8
			D	C	B	A										90.8	255.9
				D	C	B	A									98.5	285.0
					D	C	B	A								105.2	314.6
						D	C	B	A							111.9	344.1
							D	C	B	A						129.6	369.3
								D	C	B	A					137.3	398.4
									D	C	B	A				145.0	427.6
										C						151.7	457.1
											A					162.3	486.6
											B	A				169.0	516.1
											C	B	A			183.7	540.9
												C	B			195.4	570.1
													C			211.5	658.7

\* For applications that require leakage distance, height or terminal size requirements not listed, please contact your Hubbell Power Systems Representative at 1.573.682.5521.



# Products – High Strength Polymer Housed Surge Arresters – SVNH & SVNX

SVNH arresters are available for use on system voltages from 161 to 500 kV. These arresters offer a high strength alternative to the SVN arresters, without sacrificing protective capability or energy handling capability.

## SVNH Electrical Characteristics

Standard Arrester Catalog Number	Duty Cycle Rating (kV rms)	MCOV Maximum Continuous Operating Voltage (kV rms)	Maximum 0.5 $\mu$ s Discharge Voltage (kV) @ 20 kA	Maximum Switching Surge Protective Level (kV) *	TOV Capability (No Prior Duty)		Maximum Discharge Voltage using an 8/20 Current Wave (kV)					
					1 sec (kV rms)	10 sec (kV rms)	1.5kA	3kA	5kA	10kA	20kA	40kA
SVNH144GA115	144	115	383.0	279.9	170.0	163.1	293.6	304.0	314.5	330.4	352.5	387.9
SVNH168GA131	168	131	436.0	318.8	193.6	185.8	334.4	346.3	358.3	376.4	401.6	441.9
SVNH172GA140	172	140	466.0	340.7	206.9	198.5	357.4	370.1	382.9	402.2	429.2	472.2
SVNH180GA144	180	144	479.0	350.4	212.8	204.2	367.6	380.6	393.9	413.7	441.4	485.7
SVNH192GA152	192	152	506.0	369.9	224.7	215.5	388.0	401.8	415.7	436.7	466.0	512.7
SVNH240GA190	240	190	632.0	462.4	280.8	269.4	485.0	502.2	519.7	545.9	582.5	640.9
SVNH258GA209	258	209	695.0	526.6	308.9	296.4	533.5	552.4	571.7	600.5	640.7	705.0
SVNH264GA212	264	212	705.0	534.2	313.3	300.6	541.2	560.4	579.9	609.1	649.9	715.1
SVNH276GA220	276	220	732.0	554.3	325.2	312.0	561.6	581.5	601.7	632.1	674.4	742.1
SVNH288GA230	288	230	765.0	579.5	339.9	326.1	587.1	607.9	629.1	660.8	705.1	775.8
SVNH294GA235	294	235	781.0	592.1	347.3	333.2	599.9	621.2	642.8	675.2	720.4	792.7
SVNH312GA245	312	245	815.0	617.3	362.1	347.4	625.4	647.6	670.1	703.9	751.1	826.4
SVNH396GA318	396	318	1171.0	801.3	470.0	450.9	811.8	840.6	869.8	913.6	974.9	1072.6
SVNH420GA335	420	335	1234.0	844.1	495.1	475.0	855.2	885.5	916.3	962.5	1027.0	1130.0
SVNH444GA353	444	353	1300.0	889.5	521.7	500.6	901.1	933.1	965.5	1014.2	1082.2	1190.7

The new SVNX arresters are lightweight and are more resistant to fragmenting than traditional porcelain arresters. SVNX arresters are typically applied to system voltages higher than 500 kV where the energy requirements are higher than required for lower voltage systems.

## SVNX Electrical Characteristics

Standard Arrester Catalog Number	Duty Cycle Rating (kV rms)	MCOV Maximum Continuous Operating Voltage (kV rms)	Maximum 0.5 $\mu$ s Discharge Voltage (kV) @ 20 kA	Maximum Switching Surge Protective Level (kV) *	TOV Capability (No Prior Duty)		Maximum Discharge Voltage using an 8/20 Current Wave (kV)					
					1 sec (kV rms)	10 sec (kV rms)	1.5kA	3kA	5kA	10kA	20kA	40kA
SVNX396GA318AA	396	318	970	774	462	442	768	795	820	859	911	975
SVNX420GA335AA	420	335	1022	815	487	466	809	837	863	905	959	1027
SVNX444GA353AA	444	353	1077	859	513	491	853	882	910	954	1011	1082
SVNX588GA470AA	588	470	1434	1144	683	654	1135	1175	1211	1270	1346	1441

\* Discharge voltages are based on 2,000 A.



# Products – High Strength Polymer Housed Surge Arresters – SVNH & SVNX

## SVNH Physical Characteristics

Standard Arrester Catalog Number	Duty Cycle Rating (kV rms)	MCOV Maximum Continuous Operating Voltage (kV rms)	Height Dimension (Inches)	Leakage Distance (Inches)	Drawing Figure	Recommended Minimum Clearance (Inches)		Net Weight (Pounds)
						Ph - Ph	Ph - Gd	
SVNH144GA115	144	115	68.9	184.1	1	28.9	25.1	346
SVNH168GA131	168	131	68.9	184.1	1	33.1	28.8	350
SVNH172GA140	172	140	68.9	184.1	1	35.4	30.9	353
SVNH180GA144	180	144	78.8	224.6	2	36.5	31.8	401
SVNH192GA152	192	152	78.8	224.6	2	38.6	33.6	404
SVNH240GA190	240	190	112	284.6	3	48.5	42.5	607
SVNH258GA209	258	209	112	284.6	3	53.5	46.9	614
SVNH264GA212	264	212	112	284.6	3	54.3	47.6	615
SVNH276GA220	276	220	112	284.6	3	56.4	49.4	617
SVNH288GA230	288	230	122	326.4	3	59.0	51.7	651
SVNH294GA235	294	235	122	326.4	3	60.3	52.9	652
SVNH312GA245	312	245	122	326.4	3	62.9	55.2	656
SVNH396GA318	396	318	152	449.1	3	82.1	72.1	828
SVNH420GA335	420	335	176	468.7	4	86.5	76.1	993
SVNH444GA353	444	353	176	468.7	4	91.2	80.2	998

These arresters are typically applied to system voltages higher than 500 kV where the energy requirements are higher than required for lower voltage systems. If a high energy rated arrester is required for a lower system voltage, Hubbell Power Systems can provide these. Please contact your Hubbell Power Systems Representative at 1.573.682.5521 for more information.

## SVNX Physical Characteristics

Standard Arrester Catalog Number	Duty Cycle Rating (kV rms)	MCOV Maximum Continuous Operating Voltage (kV rms)	Height Dimension (Inches)	Leakage Distance (Inches)	Drawing Figure	Recommended Minimum Clearance (Inches)		Net Weight (Pounds)
						Ph - Ph	Ph - Gd	
SVNX396GA318AA	396	318	152.0	449	3	77	67	1080
SVNX420GA335AA	420	335	175.8	469	4	81	71	1285
SVNX444GA353AA	444	353	175.8	469	4	85	75	1294
SVNX588GA470AA	588	470	259.1	736	5	114	100	1847



# Products – High Strength Polymer Housed Surge Arresters – SVNH & SVNX

## Grading Ring Diameters

Arrester MCOV	Drop (A) (inches)	Diameter (B) (inches)
140–190	15.0	25.0
209–245	18.0	39.0
318–448	35.8	60.0

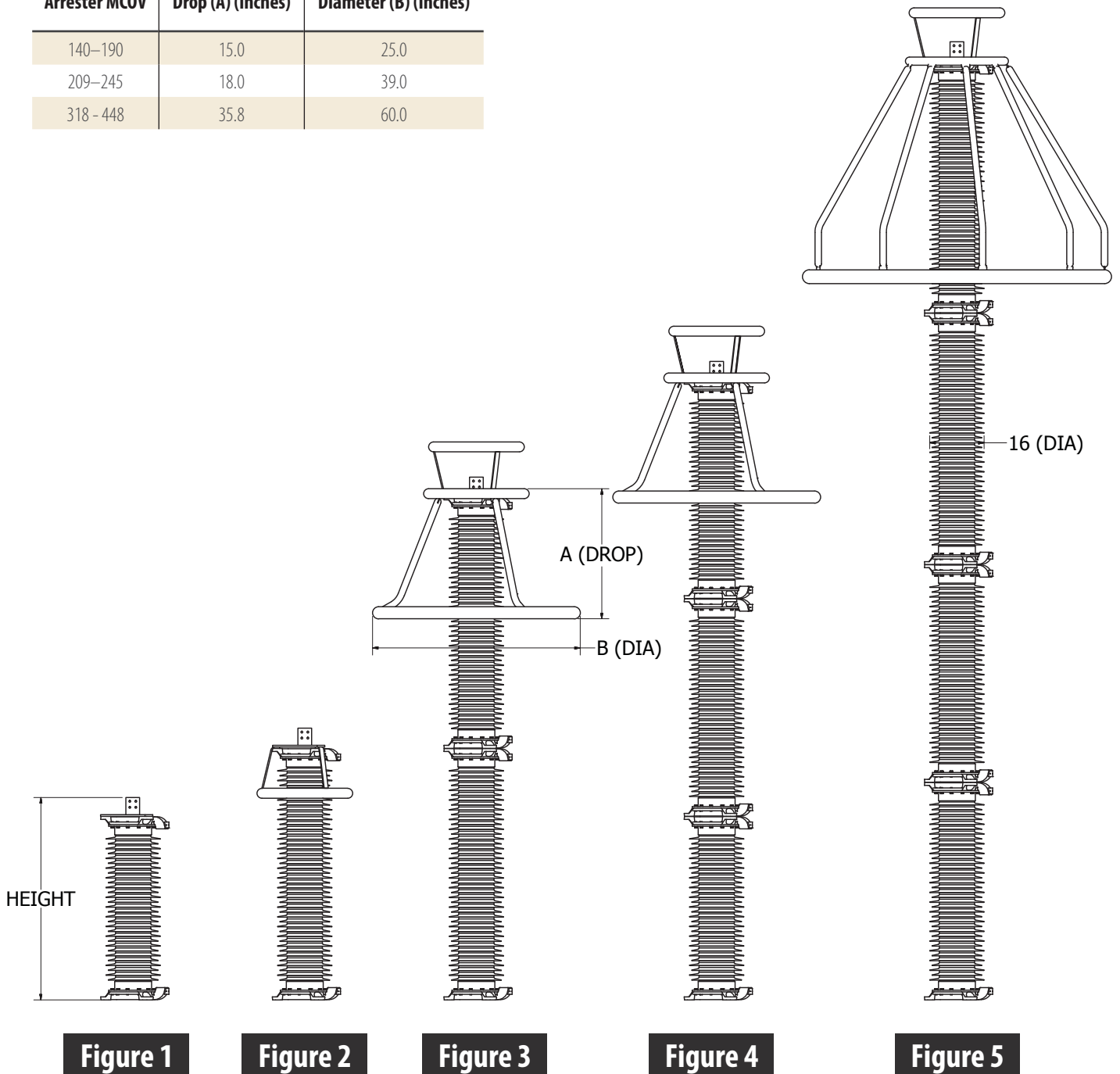

Figure 1

Figure 2

Figure 3

Figure 4

Figure 5



# Products – High Strength Polymer Housed Surge Arresters – SVNH & SVNX

## SVNH & SVNX Part Numbers

**S V N H 3 9 6 G A 3 1 8 A A**

### Step 1: Select Standard Part Number

Use Column 1 of Page 22 to select a standard part number and arrester type, including Duty Cycle and MCOV ratings.

### Duty Cycle Rating

### Step 2: Configurations

G – Standard  
U – Underhung

### Step 3: Leakage Distance Requirement

A – Standard Leakage Distance  
B - High Leakage Distance  
C - Extra High Leakage Distance

### MCOV Rating

### Step 4: Line Terminals

A – Standard

Line Size (in)	Code
0.25 – 0.81	A
0.38 – 1.12	B

### Step 5: Ground Terminals

A – Standard

Ground Size (in)	Code
0.25 – 0.81	A
0.38 – 1.12	B

\* See page 36 for hardware details.

Letter Code	MCOV							Height (in)	Leakage Distance (in)
	115 131	144 152	190 220	230 245	318	335 353	470		
A								68.9	184.1
B	A							78.8	224.6
C	B	A						112.4	284.6
	C	B	A					122.4	326.4
		C	B					132.3	368.2
			C					142.2	408.7
				A				152.0	449.1
				B	A			175.8	468.7
				C	B			185.7	510.5
					C			195.7	552.3
						A		259.1	736.4
						B		268.9	776.9
						C		278.8	817.3

\* For applications that require leakage, height or terminal size requirements not listed, please contact your Hubbell Power Systems Representative at 1.573.682.5521.



# Porcelain Housed Surge Arresters



capacity



# Products – Porcelain Housed Surge Arresters

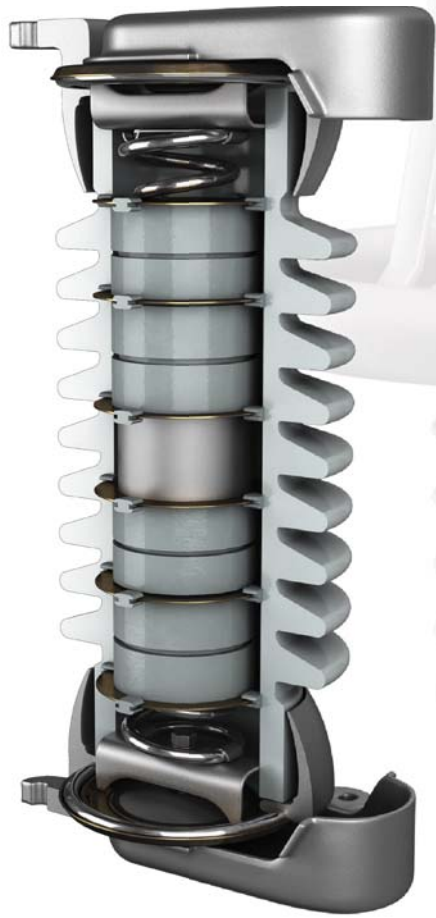

## VL & MVN, Station Class

**Overview** – Porcelain housed surge arresters have been the standard in the industry for the last 50 years. The VL/MVN family of surge arresters continue in this proud tradition and they are available for use on system voltages from 2.4 kV to 500 kV (2.52 kV max to 550 kV max). They offer high mechanical strength compared to polymer housed station class surge arresters. Additionally, the MVN family (up to 353 kV MCOV) meets the requirements for High Seismic Performance per IEEE Standard 693-2005.

### Construction:

- Porcelain housing for maximized mechanical performance
- Single column of MOV discs and aluminum spacers (as required) centrally located within housing
- Disc column held under high spring compression between ductile iron end fittings affixed to housing
- Directional pressure relief system built integrated into end fittings

### At-a-Glance:

- Operate at altitudes up to 12,000 feet/3,600 meters
- Designed to withstand winds up to 120 mph
- High cantilever strength for windstorms or earthquakes

## Summary Table Comparison

Product Line	Voltage Rating (kV rms)	MCOV (kV rms)	Energy Capability (kJ/kV-MCOV)*	Rated Short Circuit Current (Pressure Relief) (kA rms)	Maximum Working Cantilever (in-lb)	Maximum Short-Term Cantilever (in-lb)
VL	3 - 48	2.55 - 39	9	65	28,000	70,000
MVN	12 - 444	10.2 - 353	11	65	60,000	150,000

\* Energy imparted to the arrester over a one minute period, from which the arrester can thermally recover at MCOV under usual service conditions.

## Flash Fact:

**Dual rated surge arresters are available to protect equipment that may operate at more than one system voltage.**

# Products – Porcelain Housed Surge Arresters – VL

## VL Electrical Characteristics

Standard Arrester Catalog Number	Duty Cycle Rating (kV rms)	MCOV Maximum Continuous Operating Voltage (kV rms)	Maximum 0.5 $\mu$ s Discharge Voltage (kV) @ 10 kA	Maximum Switching Surge Protective Level (kV) *	TOV Capability (No Prior Duty)		Maximum Discharge Voltage using an 8/20 Current Wave (kV)					
					1 sec (kV rms)	10 sec (kV rms)	1.5kA	3kA	5kA	10kA	20kA	40kA
216003-3001	3	2.55	9.1	6.3	3.7	3.5	6.9	7.2	7.5	8.0	9.0	10.3
216005-3001	6	5.1	17.9	12.4	7.4	7.0	13.6	14.2	14.8	15.8	17.7	20.3
219508-3001	9	7.65	26.6	18.4	11.1	10.5	20.2	21.1	22.0	23.5	26.4	30.2
219509-3001	10	8.4	29.3	20.3	12.1	11.6	22.2	23.3	24.2	25.9	29.1	33.3
219510-3001	12	10.2	35.5	24.6	14.7	14.0	26.9	28.2	29.4	31.4	35.2	40.4
219513-3001	15	12.7	44.2	30.6	18.4	17.5	33.5	35.1	36.6	39.1	43.9	50.3
216015-3001	18	15.3	53.3	36.8	22.1	21.0	40.4	42.3	44.1	47.1	52.8	60.6
219517-3001	21	17	59.1	40.9	24.6	23.4	44.8	46.9	48.9	52.3	58.7	67.2
219519-3001	24	19.5	67.8	46.9	28.2	26.8	51.4	53.8	56.1	60.0	67.3	77.1
216022-3001	27	22	76.5	52.9	31.8	30.3	58.0	60.8	63.3	67.7	75.9	87.0
216024-3001	30	24.4	84.9	58.7	35.3	33.6	64.3	67.4	70.3	75.1	84.2	96.5
219529-3001	36	29	101.0	69.7	41.9	39.9	76.4	80.0	83.4	89.2	100.0	115.0
216031-3001	39	31.5	110.0	75.8	45.5	43.3	83.0	86.9	90.6	96.9	109.0	125.0
219536-3001	45	36.5	128.0	88.3	52.7	50.2	96.8	102.0	106.0	113.0	127.0	146.0
219539-3001	48	39	136.0	93.8	56.4	53.6	103.0	108.0	113.0	120.0	135.0	155.0

\* 500A surge of 45  $\mu$ s time to crest.

### Flash Fact:

**Porcelain arresters with nameplates older than 1977 are Silicon Carbide designs.**



# Products – Porcelain Housed Surge Arresters – VL

## VL Physical Characteristics

Standard Arrester Catalog Number	Duty Cycle Rating (kV rms)	MCOV Maximum Continuous Operating Voltage (kV rms)	Height Dimension (Inches)	Leakage Distance (Inches)	Recommended Minimum Clearance (Inches)		Net Weight (Pounds)
					Ph - Ph	Ph - Gd	
216003-3001	3	2.55	19.13	6.2	12.0	6.0	65
216005-3001	6	5.1	19.13	6.2	12.0	7.0	65
219508-3001	9	7.65	19.13	6.2	13.0	7.0	66
219509-3001	10	8.4	19.13	6.2	13.0	8.0	66
219510-3001	12	10.2	21.13	11.1	14.0	8.5	72
219513-3001	15	12.7	21.13	11.1	14.0	8.5	73
216015-3001	18	15.3	24.13	20.0	16.0	9.0	80
219517-3001	21	17	24.13	20.0	16.0	9.0	81
219519-3001	24	19.5	24.13	20.0	17.0	11.0	82
216022-3001	27	22	28.13	31.7	18.0	12.0	90
216024-3001	30	24.4	28.13	31.7	18.0	12.0	91
219529-3001	36	29	28.13	31.7	20.0	14.0	93
216031-3001	39	31.5	31.88	41.0	21.0	14.0	105
219536-3001	45	36.5	31.88	41.0	21.0	15.0	107
219539-3001	48	39	31.88	41.0	20.0	15.0	109

## VL Part Numbers

Standard hardware end code is -3001.

- **Top:** Two Single eye-bolts for 4-hole suspension cap
- **Bottom:** Single eye-bolt

\* See page 36 for additional hardware details.

For additional hardware options or non-standard configurations including extra leakage distance or height, please contact your Power Systems Representative at 1.573.682.5521.

## VL Detail

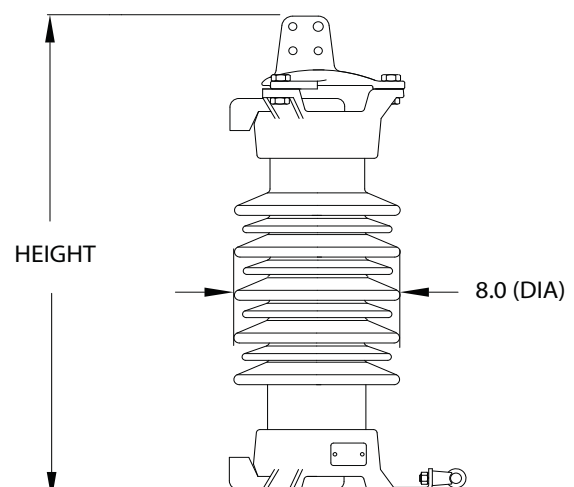

# Products – Porcelain Housed Surge Arresters – MVN

## MVN Electrical Characteristics

Standard Arrester Catalog Number	Duty Cycle Rating (kV rms)	MCOV Maximum Continuous Operating Voltage (kV rms)	Maximum 0.5µs Discharge Voltage (kV) @ 10 kA	Maximum Switching Surge Protective Level (kV) *	TOV Capability (No Prior Duty)		Maximum Discharge Voltage using an 8/20 Current Wave (kV)					
					1 sec (kV rms)	10 sec (kV rms)	1.5kA	3kA	5kA	10kA	20kA	40kA
MVN012GA010AA	12	10.2	32.1	24.4	15.2	14.5	26.2	27.3	28.2	29.6	31.6	34.8
MVN015GA013AA	15	12.7	39.9	30.3	18.9	18.1	32.6	33.9	35.1	36.8	39.3	43.3
MVN018GA015AA	18	15.3	48.2	36.5	22.8	21.8	39.3	40.9	42.3	44.4	47.4	52.5
MVN021GA017AA	21	17	53.5	40.6	25.3	24.2	43.7	45.4	47.0	49.3	53.0	58.0
MVN024GA019AA	24	19.5	62.0	46.9	29.1	27.7	50.5	52.5	54.5	57.0	61.0	67.0
MVN027GA022AA	27	22	69.5	53.0	32.8	31.3	57.0	59.0	61.0	64.0	68.5	75.5
MVN030GA024AA	30	24.4	77.0	58.5	36.4	34.7	63.0	65.5	68.0	71.0	76.0	83.5
MVN036GA029AA	36	29	92.0	69.5	43.2	41.3	75.0	78.0	80.5	84.5	90.5	99.5
MVN039GA031AA	39	31.5	99.5	75.5	46.9	44.8	81.0	84.5	87.5	91.5	98.0	108
MVN045GA036AA	45	36.5	115.0	87.5	54.5	52.0	94.0	98.0	101.0	106.0	114.0	125.0
MVN048GA039AA	48	39	124.0	94.0	58.0	55.5	101.0	105.0	109.0	114.0	122.0	134.0
MVN054GA042AA	54	42	133.0	101.0	62.5	60.0	108.0	113.0	117.0	122.0	131.0	144.0
MVN060GA048AA	60	48	152.0	116.0	71.5	68.5	124.0	129.0	134.0	140.0	150.0	165.0
MVN066GA053AA	66	53	167.0	127.0	79.0	75.5	137.0	142.0	147.0	154.0	165.0	181.0
MVN072GA057AA	72	57	180.0	137.0	85.0	81.0	147.0	153.0	159.0	166.0	178.0	195.0
MVN090GA070AA	90	70	221.0	167.0	104.0	99.5	180.0	187.0	194.0	203.0	217.0	239.0
MVN090GA074AA	90	74	234.0	177.0	110.0	105.0	191.0	198.0	205.0	215.0	230.0	253.0
MVN096GA076AA	96	76	240.0	182.0	113.0	108.0	196.0	204.0	211.0	221.0	236.0	260.0
MVN108GA084AA	108	84	265.0	201.0	125.0	120.0	216.0	225.0	233.0	244.0	261.0	287.0
MVN108GA088AA	108	88	277.0	210.0	131.0	125.0	226.0	235.0	243.0	255.0	273.0	300.0
MVN120GA098AA	120	98	308.0	241.0	146.0	139.0	252.0	262.0	271.0	284.0	304.0	334.0
MVN126GA102AA	126	102	321.0	251.0	152.0	145.0	262.0	273.0	282.0	296.0	316.0	348.0
MVN132GA106AA	132	106	334.0	261.0	158.0	151.0	273.0	284.0	294.0	308.0	329.0	362.0
MVN144GA115AA	144	115	363.0	283.0	171.0	164.0	296.0	308.0	318.0	334.0	357.0	393.0
MVN168GA131AA	168	131	412.0	322.0	195.0	186.0	337.0	350.0	362.0	380.0	406.0	447.0
MVN172GA140AA	172	140	441.0	344.0	209.0	199.0	360.0	374.0	387.0	406.0	434.0	477.0
MVN180GA144AA	180	144	454.0	355.0	215.0	205.0	370.0	385.0	398.0	418.0	447.0	491.0
MVN192GA152AA	192	152	479.0	374.0	226.0	216.0	391.0	406.0	420.0	441.0	471.0	518.0
MVN202GA161AA	202	161	507.0	396.0	240.0	229.0	414.0	430.0	445.0	467.0	499.0	549.0
MVN216GA168AA	216	168	528.0	413.0	250.0	239.0	431.0	449.0	464.0	487.0	520.0	572.0
MVN228GA180AA	228	180	566.0	443.0	268.0	256.0	462.0	481.0	497.0	522.0	557.0	613.0
MVN240GA190AA	240	190	598.0	467.0	283.0	270.0	488.0	507.0	525.0	551.0	588.0	647.0
MVN258GA209AA	258	209	657.0	532.0	311.0	297.0	537.0	558.0	577.0	606.0	647.0	712.0
MVN264GA212AA	264	212	667.0	540.0	316.0	302.0	545.0	566.0	586.0	615.0	657.0	723.0
MVN276GA220AA	276	220	692.0	560.0	328.0	313.0	565.0	587.0	608.0	638.0	681.0	750.0
MVN288GA230AA	288	230	724.0	585.0	343.0	327.0	591.0	614.0	635.0	667.0	712.0	784.0
MVN294GA235AA	294	235	739.0	598.0	350.0	334.0	603.0	627.0	649.0	681.0	727.0	800.0
MVN300GA243AA	300	243	765.0	619.0	362.0	346.0	624.0	649.0	672.0	705.0	753.0	828.0
MVN312GA245AA	312	245	770.0	623.0	365.0	349.0	629.0	654.0	676.0	710.0	758.0	834.0
MVN336GA274AA	336	274	861.0	697.0	408.0	390.0	703.0	731.0	756.0	794.0	848.0	933.0
MVN360GA288AA	360	288	906.0	733.0	429.0	410.0	739.0	769.0	795.0	835.0	891.0	981.0
MVN396GA318AA	396	318	1053.0	809.0	474.0	453.0	816.0	849.0	878.0	922.0	984.0	1083.0
MVN420GA335AA	420	335	1109.0	852.0	499.0	477.0	860.0	894.0	925.0	971.0	1037.0	1140.0
MVN444GA353AA	444	353	1169.0	898.0	526.0	502.0	906.0	942.0	974.0	1023.0	1092.0	1202.0

\* Discharge voltages are based on a 500A surge of 45 µs time to crest through 88 kV MCOV and 1,000A surge of 45 µs time through 190 kV MCOV and 2,000A through 353 kV MCOV.



# Products – Porcelain Housed Surge Arresters – MVN

## MVN Physical Characteristics

Standard Arrester Catalog Number	Duty Cycle Rating (kV rms)	MCOV Maximum Continuous Operating Voltage (kV rms)	Height Dimension (Inches)	Leakage Distance (Inches)	Drawing Figure	Recommended Minimum Clearance (Inches)		Net Weight (Pounds)
						Ph - Gd	Ph - Ph	
MVN012GA010AA	12	10.2	31.7	43.9	1	1.4	0.8	129
MVN015GA013AA	15	12.7	31.7	43.9	1	2.1	1.4	131
MVN018GA015AA	18	15.3	31.7	43.9	1	2.8	2.0	132
MVN021GA017AA	21	17	31.7	43.9	1	3.3	2.4	133
MVN024GA019AA	24	19.5	31.7	43.9	1	4.0	3.0	134
MVN027GA022AA	27	22	31.7	43.9	1	4.6	3.6	136
MVN030GA024AA	30	24.4	31.7	43.9	1	5.2	4.2	137
MVN036GA029AA	36	29	31.7	43.9	1	6.5	5.3	140
MVN039GA031AA	39	31.5	31.7	43.9	1	7.1	5.8	141
MVN045GA036AA	45	36.5	38.1	75.0	1	8.5	7.0	172
MVN048GA039AA	48	39	38.1	75.0	1	9.2	7.6	174
MVN054GA042AA	54	42	38.1	75.0	1	9.9	8.3	176
MVN060GA048AA	60	48	38.1	75.0	1	11.6	9.8	179
MVN066GA053AA	66	53	38.1	75.0	1	12.9	10.9	181
MVN072GA057AA	72	57	38.1	75.0	1	14.0	11.9	184
MVN090GA070AA	90	70	44.1	100.0	1	17.3	14.8	218
MVN090GA074AA	90	74	44.1	100.0	1	18.4	15.8	220
MVN096GA076AA	96	76	44.1	100.0	1	18.9	16.3	221
MVN108GA084AA	108	84	50.6	126.3	1	21.1	18.1	257
MVN108GA088AA	108	88	50.6	126.3	1	22.1	19.1	258
MVN120GA098AA	120	98	50.6	126.3	1	24.7	21.4	264
MVN126GA102AA	126	102	57.1	152.5	1	25.8	22.3	294
MVN132GA106AA	132	106	57.1	152.5	1	26.9	23.3	295
MVN144GA115AA	144	115	57.1	152.5	1	29.3	25.4	300
MVN168GA131AA	168	131	76.6	175.0	2	33.5	29.1	392
MVN172GA140AA	172	140	76.6	175.0	2	35.8	31.2	415
MVN180GA144AA	180	144	82.6	200.0	3	37.0	32.2	443
MVN192GA152AA	192	152	82.6	200.0	3	39.0	34.0	448
MVN202GA161AA	202	161	89.1	226.3	3	41.4	36.1	485
MVN216GA168AA	216	168	89.1	226.3	3	43.2	37.7	488
MVN228GA180AA	228	180	95.6	252.5	3	46.4	40.5	525
MVN240GA190AA	240	190	95.6	252.5	3	49.0	42.9	531
MVN258GA209AA	258	209	102.1	278.8	3	54.1	47.3	575
MVN264GA212AA	264	212	102.1	278.8	3	54.9	48.1	577
MVN276GA220AA	276	220	108.6	305.0	3	57.0	49.9	608
MVN288GA230AA	288	230	108.6	305.0	3	59.6	52.3	613
MVN294GA235AA	294	235	127.6	326.3	4	60.9	53.4	700
MVN300GA243AA	300	243	127.6	326.3	4	63.1	55.4	704
MVN312GA245AA	312	245	127.6	326.3	4	63.5	55.7	705
MVN336GA274AA	336	274	134.1	352.5	4	71.2	62.5	751
MVN360GA288AA	360	288	140.6	378.8	4	74.9	65.8	790
MVN396GA318AA	396	318	153.6	431.3	4	82.9	72.8	892
MVN420GA335AA	420	335	160.1	457.6	4	87.4	76.8	928
MVN444GA353AA	444	353	179.1	478.8	5	92.1	81.0	1026



# Products – Porcelain Housed Surge Arresters – MVN

## MVN Detail

### Grading Ring Diameters

Arrester MCOV	Drop (A) (inches)	Diameter (B) (inches)
140–190	15.0	25.0
209–245	18.0	39.0
318–353	35.8	60.0

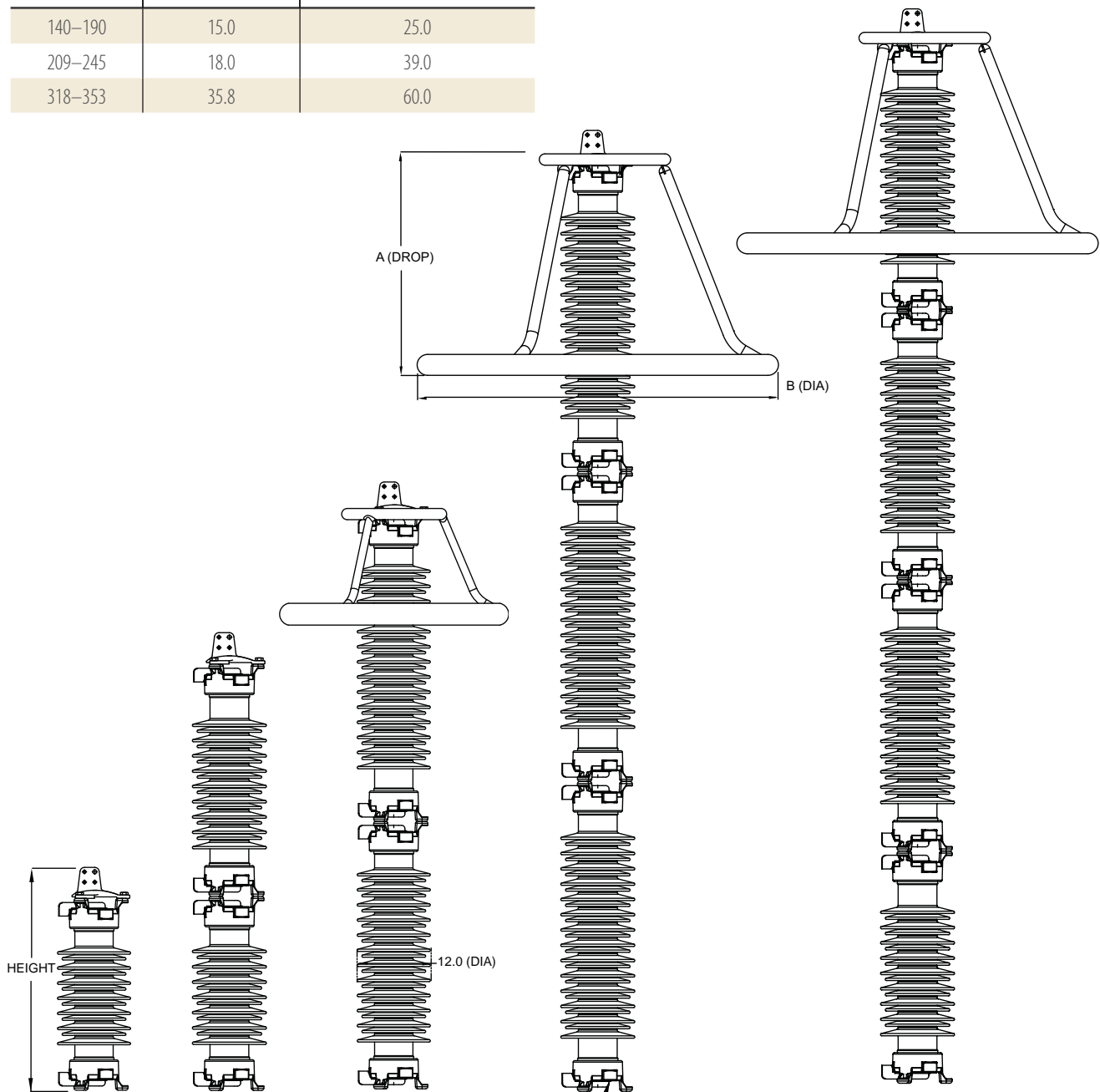

Figure 1

Figure 2

Figure 3

Figure 4

Figure 5



# Products – Porcelain Housed Surge Arresters – MVN

## MVN Part Number Selection

M V N 0 5 4 G A 0 4 2 A A

### Step 1: Select Standard Part Number

Use Column 1 of Page 30 to select a standard part number, including Duty Cycle and MCOV ratings.

### Duty Cycle Rating

### Step 2: Housing/Color Configuration

- G – Gray Housing (standard)
- B – Brown Housing
- U – Underhung (with std housing color)

### Step 3: Leakage Distance Requirement

- A - Standard Leakage Distance
- B - High Leakage Distance
- C - Extra High Leakage Distance
- D - Mega High Leakage Distance

### Step 4: Line Terminals

A – Standard

Line Size (in)	Code
0.25 – 0.81	A
0.38 – 1.12	B

### Step 5: Ground Terminals

A – Standard

Ground Size (in)	Code
0.25 – 0.81	A
0.38 – 1.12	B

\* See page 36 for hardware details.

Letter Code	MCOV													Height (in)	Leakage Distance (in)	
	10.2 31.5	042 057	070 076	084 098	106 115	131 140	144 152	180 190	209 212	220 230	245	318	335			353
A															31.7	43.9
B	A														38.1	75.0
C	B	A													44.1	100.0
D	C	B	A												50.6	126.3
	D	C	B	A											57.1	152.5
		D	C	B	A										76.6	175.0
			D	C	B	A									82.6	200.0
				D	C	B	A								89.1	226.3
					D	C	A								95.6	252.5
						D	B	A							102.1	278.8
							C	B	A						108.6	305.0
								D	C	B	A				127.6	326.3
									D	C	B				134.1	352.5
										D	C				140.6	378.8
												A			153.6	431.3
												B	A		160.1	457.6
													B	A	179.1	478.8
														B	185.6	505.0

\* For applications that require leakage, height or terminal size requirements not listed, please contact your Hubbell Power Systems Representative at 1.573.682.5521.



# General Information

**Packaging** – All MVN and SVN arresters are packed in a wooden crate compatible for forklift use. SVN and SVNH arvester units are shipped vertically, with multiple units bolted to a pallet and crated. Most VL and VLA arresters are packed with each porcelain unit in a separate cardboard carton. EVP arresters above 98kV MCOV will be packaged in a wooden crate compatible for forklift use. All other EVP and PVI-LP arresters will be packaged in a cardboard carton.

All packaging includes proper labeling for correct assembly upon construction. Stacking bolts, when required, are included. If needed, grading rings are packed, shipped separately, and tagged for easy identification.

Base Mounting Summary Table				
Product Line	Bolt Circle (in)	Bolt Size (in)	Attachment Lug	
			Thickness (in)	Hole Size (in)
PVI-LP	8.75 – 10	0.5	0.75	0.56 slotted
EVP	8.75 – 10	0.5	1.25	0.56 slotted
VL, MVN, SVN	10	0.5	0.63	0.56
SVNX, SVNH	16.5	0.75	0.88	0.81 x 1.11 slotted

**Base Mounting Information** – PVI-LP and EVP end castings are furnished with three slotted holes for 8.75" to 10" diameter bolt circles, 120 degrees apart. End castings of types VL, MVN, and SVN arresters are furnished with three holes, 120 degrees on a 10" diameter bolt circle. End castings for the SVNX and SVNH type arresters are furnished with 3 holes, 120 degrees apart on a 16.5" bolt circle.

Mounting holes will accommodate 1/2 or 3/4 inch bolts. Rated cantilever strength is achieved with the use of 1/2 or 3/4 inch bolts. Mounting bolts, nuts, and washers are not furnished with arresters.

**Horizontal Mounting of Arresters** – Many Hubbell Power Systems substation arresters can be mounted horizontally. The first consideration is the cantilever force at the mounting point not exceed the cataloged rated working cantilever load of the arvester under consideration. This force is a calculation of the total weight of the arvester multiplied by 50% of the total height of the arvester.

Other considerations such as how much residual strength is available for large conductor loading, ice loading and wind loading require a more detailed analysis. In these cases please contact your Hubbell Power Systems Representative at 1.573.682.5521 for technical assistance.



# Accessories / Hardware

## Nameplates:

- Each arrester is identified with an arrester nameplate attached to its bottom casting.
- Arrester nameplates display the MCOV, duty cycle rating, pressure relief current, serial and catalog numbers as required by IEEE and IEC.
- On multiple-unit stacks, the plate is attached to the bottom unit. It features all of the same information as well as the stacking sequence.
- Multiple-unit arresters must be stacked in the order listed on the base nameplate. The stacking sequence is also listed on the arrester crates for easy reference.
- Additionally, multiple-unit stacks feature a unit nameplate on the upper casting of each unit. This identifies the serial number of the specific unit.

**HUBBELL OHIO BRASS** SURGE ARRESTER STATION  
POWER SYSTEMS

TYPE \_\_\_\_\_ CAT# \_\_\_\_\_

SER# \_\_\_\_\_ UNIT STACKING ORDER TOP

○ MCOV \_\_\_\_\_ kV RMS

48-62Hz RATED \_\_\_\_\_ kV RMS

Short Circuit \_\_\_\_\_ kA RMS

MFR YEAR \_\_\_\_\_ BOT

HUBBELL POWER SYSTEMS, INC.  
AIKEN, SOUTH CAROLINA • WADSWORTH, OHIO USA

**Station Arrester Nameplate**

**HUBBELL OHIO BRASS** SURGE ARRESTER UNIT  
POWER SYSTEMS

○ UNIT MCOV ○

○ UNIT SERIAL# ○

UNIT ASSY#

HUBBELL POWER SYSTEMS, INC.  
AIKEN, SOUTH CAROLINA • WADSWORTH, OHIO USA

**Arrester Unit Nameplate**

**HUBBELL OHIO BRASS**  
POWER SYSTEMS

PVI-LP Intermediate Surge Arrester 10 KA CLASS 2  
Short Circuit 40 kA rms 48-62 Hz

CATALOG NUMBER \_\_\_\_\_

DUTY CYCLE RATING \_\_\_\_\_ kV RMS

MCOV RATING \_\_\_\_\_ kV RMS

YEAR \_\_\_\_\_

AIKEN, SC • WADSWORTH, OH U.S.A.

**PVILP Nameplate**

**HUBBELL OHIO BRASS** EVP STATION CLASS ARRESTER  
POWER SYSTEMS AIKEN, SC WADSWORTH, OHIO USA

CAT#	RATING (Ur) kV RMS 48-62 Hz	YR	10KA CLASS 3
SER#	MCOV (Uc) kV RMS	SHORT CIRCUIT kA RMS	63

**EVP Nameplate**



# Accessories / Hardware

## Counters:

- Arrester discharge counters can be provided with or without a built-in milliamp meter to provide a continuous grading current reading.
- Operation of an arrester discharge counter and the optional grading current instrument requires that the arrester base be insulated from the ground. Insulating subbases are required to mount the discharge counter.

**Counters Summary Table**

Counter Catalog Number	Leakage Current Meter	Range of mA Reading	Max No. Counts	Min Count Current	Max High Current Withstand	Nominal Residual Voltage
245150 / 245120	No	N/A	999,999	200 A (8/20 $\mu$ s wave)	100 kA (4/10 $\mu$ s wave)	5 kV Peak (4/10 $\mu$ s wave) @ 100kA
245151 / 245121	Yes	0 – 30	999,999	200 A (8/20 $\mu$ s wave)	100 kA (4/10 $\mu$ s wave)	5 kV Peak (4/10 $\mu$ s wave) @ 100kA

**Subbases** – Arresters with discharge counters require that the arrester is insulated from the ground with insulating subbases. Each leg of the tripod base will need an insulating subbase as shown below.



**Part No. 2721453076**  
**Heavy Duty 3 Piece Insulating Subbase Assembly Kit** - For use with Type MVN and SVN arresters.

Note: A quantity of one subbase assembly kit should be ordered per arrester.



**Part No. 2730973001**  
**Normal Duty 3 Piece Insulating Subbase Assembly Kit** - For use with Type PVI-LP, EVP and VL arresters.

**Counter Kits** – Arresters Counter kits are available containing the counter and three subbases. The catalog numbers are formed by pairing the counter catalog number with SBASEHD for the heavy duty subbases and SBASEND for the normal duty subbases.



# Accessories / Hardware

**Line and Ground Terminals** – All Hubbell arresters include as standard line and ground terminals for conductors from .25 to .81 inch diameters. These are made from hot-dipped galvanized (HDG) malleable iron, compatible with either aluminum or copper.

The arrangement of mounting terminals on arresters makes it possible to align them in any direction to accommodate the angle of the incoming lead wire.

If your conductor size exceeds standard terminal capacity, contact your Hubbell Power Systems Representative at 1.573.682.5521 for an appropriate quote.

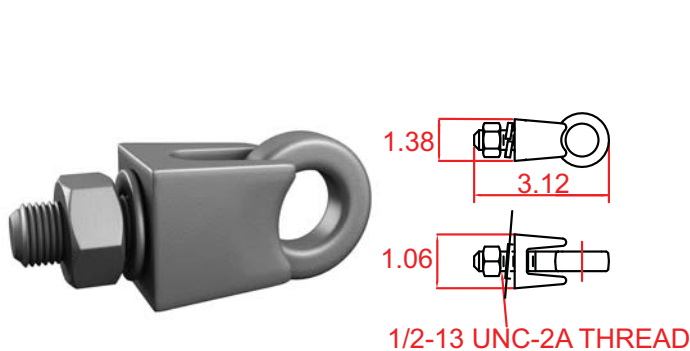

**HDG Terminal Assy, Part No. M271414-3001**  
Suitable for Cu or Al Conductor Size .25 – .81 in. diameter. (AWG#4 – 500 MCM)

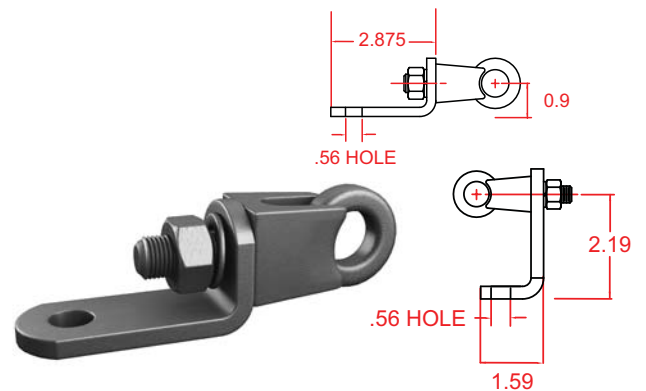

**HDG Terminal Bracket Assy, Part No. M71874-3001**  
Suitable for Cu or Al Conductor Size .25 – .81 in. diameter. (AWG#4 – 500 MCM)

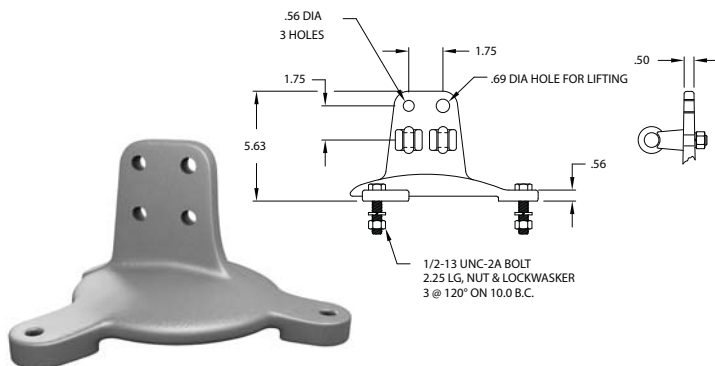

**Suspension Cap, Part No. 272087-3001K** – This cap is the standard suspension cap furnished with VL, MVN and SVN arresters.

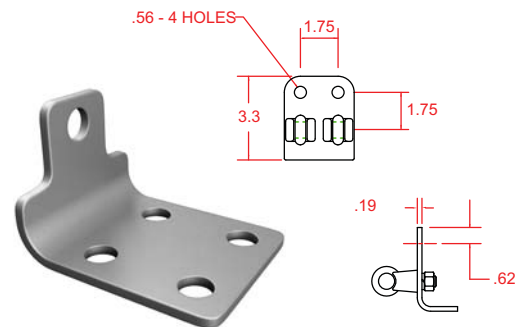

**4-Hole NEMA Pad, Part No. 274914-4002** – Line-end terminals are available with a 4-hole NEMA pad with a single eye-bolt. Single eye-bolt ground-end terminals are automatically included. The 4-hole NEMA pad is typically furnished with standard EVP & PVI-LP end codes.

**Engineering Note:** Maximum recommended tightening torque to be applied to the end stud when installing terminals and leads is 20 ft-lbs.

# Station / Intermediate Mounting Brackets

## Double Crossarm Base Mounting Plate

Part No. 718643001

(Bracket is also drilled for 10-inch bolt circle.)

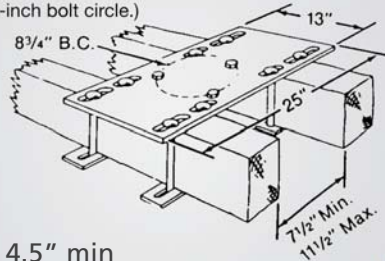

5" x 4.5" min  
8.5" x 6.5" max

Maximum arrester size that may be mounted on this bracket is 39 kV MCOV.

## Single Crossarm Mounting Bracket

Part No. 900643001

FOR CROSSARMS:  
1 1/2" x 4 1/2" Min.  
4" x 6 1/2" Max.

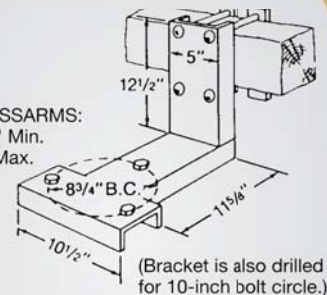

1.5" x 4.5" min  
4" x 6.5" max

Electrical clearances must be observed. Maximum arrester size that may be mounted on this bracket is 48 kV MCOV. Pipe spacers are included with attachment bolts to clear channel thickness and permit mounting the arrester with bracket in an inverted position.

## Double Crossarm Mounting Bracket

Part No. 901063001

(Bracket is also drilled for 10-inch bolt circle.)

FOR CROSSARMS:  
1 3/4" x 4 1/2" Min.  
4 1/2" x 6 1/2" Max.

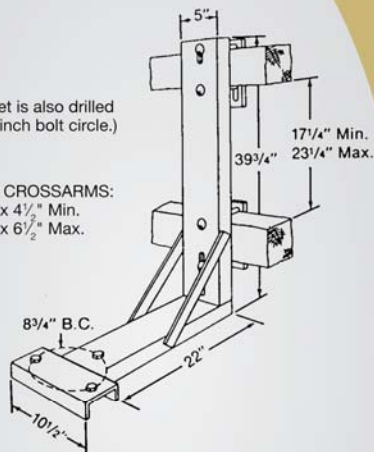

1.74" x 4.5" min  
4.5 x 6.5" max

Electrical clearances must be observed. Maximum arrester size that may be mounted on this bracket is 48 kV MCOV. Pipe spacers are included with attachment bolts to clear channel thickness and permit mounting the arrester with bracket in an inverted position.

## Wall Mounting Bracket

Part No. 718653001

(Bracket is also drilled for 10-inch bolt circle.)

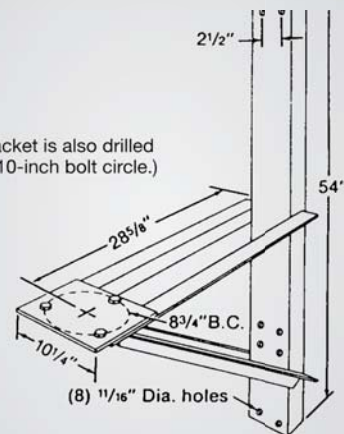

Electrical clearances must be observed. Maximum arrester size that may be mounted on this bracket is 57 kV MCOV.

# Mounting Brackets for PVI-LP and EVP Arresters

## Pole Mounting Bracket for Single Arrester

Part No. 968763001

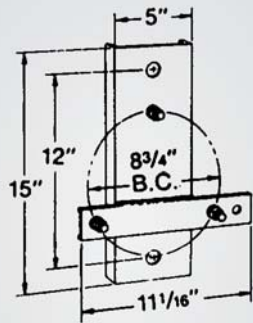

Provides horizontal arrester mounting for armless construction and cable riser poles. Electrical clearances must be observed. Maximum arrester size that may be mounted on this bracket is 57 kV MCOV.

## Pole Mounting Bracket for Three Arresters

Part No. 968753001

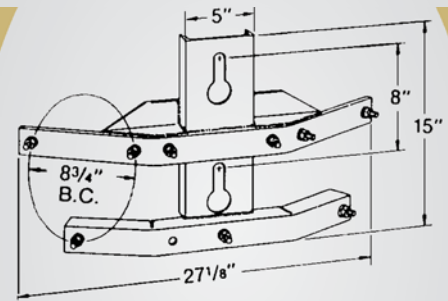

Provides horizontal arrester mounting for armless construction and cable riser poles. Electrical clearances must be observed. Maximum arrester size that may be mounted on this bracket is 57 kV MCOV.

### Flash Fact:

*Hubbell and Ohio Brass were both founded in 1888.*

# innovation

# Arrester FAQs

## 1. What is the difference between a grading ring and a corona ring?

A grading ring is used to ensure a uniform voltage distribution along the length of an electrical device. This is important for surge arresters so each MOV disc in the arrester is energized at the appropriate voltage.

A corona ring is traditionally used to electrically shield external hardware to prevent corona from developing. This corona could lead to degradation of insulating materials or create interference to electronic communication.

Surge arresters below 500 kV system voltage do not typically need corona rings.

## 2. Why are the catalog phase to phase and phase to ground clearances less than spacing in other industry codes such as the National Electric Code?

The clearances in this catalog are the minimum distances for which the uniform internal voltage distribution of the arrester will not be compromised. It is not the intention of Hubbell Power Systems to overrule a specific customer requirement. If a specific end user application dictates a larger clearance the standard Hubbell Power Systems will function properly.

## 3 Why are the heights of the arrester less than the spacing mandated in other industry codes such as the National Electric Code?

The arresters in this catalog are designed and tested in accordance with IEEE C62.11 which defines minimum insulation withstand of station class arrester. It is not the intention of Hubbell Power Systems to overrule a specific customer requirement. If a specific end user application dictates a larger spacing Hubbell Power Systems can supply a special arrester with the required spacing.

## 4. Where can I find the Design Test Report for my arrester?

Design Test Reports can be found on the Hubbell Power Systems website under the resources tab. A link is provided below. <http://www.hubbellpowersystems.com/resources/test-reports/test-reports-arresters.asp>

## 5. How do I know if I need a grading ring or corona ring for my arrester?

The Hubbell/Ohio Brass Engineers have performed all necessary electric field calculations to make this decision. Therefore, all of our surge arrester part numbers already include rings if required, and you need not specify rings. They will automatically ship with your arrester, stacked on a separate pallet.

## 6. Can Hubbell Power Systems arresters be mounted in a non-vertical configuration?

Many Hubbell Power Systems substation arresters can be mounted horizontally. The first consideration is the cantilever force at the mounting point not exceed the cataloged rated working cantilever load of the arrester under consideration. This force is a calculation of the total weight of the arrester multiplied by 50% of the total height of the arrester.

## 7. Where is the terminal hardware that comes with the arresters located?

Suspension cap and terminal hardware items are shipped unattached to the arrester and will be contained in a separate bag or box within the arrester crate. In the case of a multi-unit arrester the hardware will be in the crate of the bottom unit.

Other considerations such as how much residual strength is available for large conductor loading, grading ring loading, ice loading and wind loading require a more detailed analysis. In these cases please contact your Hubbell Power Systems representative at 1.573.682.5521 for technical assistance.

When mounting the arrester in a non vertical or under-hung position, the orientation of the sheds must be considered. If the sheds are inverted this can allow water to pool around the center of the arrester and decrease the creepage distance. This can result in increased chance of flashover.





# Arrester FAQs

## 8. What does MCOV rating of a surge arrester mean?

MCOV stands for the Maximum Continuous Operating Voltage. It represents the power frequency voltage that may be continuously applied to a surge arrester.

The MCOV selected for a given system voltage is a function of the maximum line-to-line voltage as well as the system grounding parameters. Hubbell Power Systems application engineers can assist with the proper MCOV selection for your specific requirement.

## 9. What if I need a different arrester configuration than what is offered in the catalog.

Hubbell Power Systems can offer many customization options for arresters. Options include increased creepage distances, increased height, different arrester MCOV's, various terminal sizes, higher energy rating, and mounting hardware. Contact your Hubbell Representative at 1.573.682.5521 for more information on arrester customization options.

## 10. How does MCOV rating differ from Duty Cycle rating?

The Duty Cycle rating of a surge arrester is the power frequency voltage at which the arrester can successfully withstand the duty cycle test per IEEE Standard C62.11. The Duty Cycle rating is a short-term TOV (Temporary Over Voltage) rating.

## 11. What is the difference between a station class and an intermediate arrester?

Generally, station class arresters have the lowest protective characteristics and most durability, while intermediate arresters perform at levels slightly less robust than station class arresters.

Both of these arresters have traditionally been used in sub-station applications. The arrester IEEE Standard C62.11 defines the performance levels of each of these designs.

## 12. Why is the system grounding type important to consider when selecting the MCOV rating?

The type of grounding determines the amount of neutral shift during a fault on the power system. The resulting TOV on the arrester could cause damage unless the arrester is sized properly.

Your Hubbell Power Systems Representative can help with the selection of the proper size arrester for your application.

## 13. How do I use the pressure relief rating value in making my arrester selection?

When a surge arrester fails, it will become shorted. It then will conduct the available short circuit current in the substation.

To minimize the possibility of a catastrophic failure, you should select an arrester with a pressure relief rating that is greater than the available short-circuit current in your substation.

## 14. What routine maintenance and testing does Hubbell Power Systems recommend for station class surge arresters?

Hubbell Power Systems arresters are designed to provide years of successful service without any recommended maintenance. Arresters do not require field testing; however, if testing must be performed we recommend that Hubbell Power Systems be contacted prior to beginning a testing.

## 15. I have a question that is not covered in this section.

We'll be happy to answer any of your arrester questions. Just contact your local Hubbell Power Systems Representative or call our main customer service line at 1.573-682-5521.



# Engineering Terminology

## A Glossary of Terms Used in This Catalog

**BIL (Basic Insulation Level):** The electrical strength of insulation in terms of the crest value of a standard lightning impulse under standard atmospheric conditions.

**Corona Ring:** A metal ring used to electrically shield external hardware by preventing corona discharge effects from developing. This will come with the arrester is required by design.

**Crest Value:** The maximum value that a wave, surge or impulse attains.

**Design Tests:** Tests made on each design to establish performance characteristics and to demonstrate compliance with the appropriate standards of the industry. Once made, they need not be repeated unless the design is changed so as to modify performance.

**Discharge Counter:** A device for recording the number of arrester discharge operations.

**Discharge Voltage:** The voltage that appears across the terminals of an arrester during passage of discharge current. Sometimes referred to as IR.

**Discharge Withstand Current:** The specified magnitude and wave shape of a discharge current that can be applied to an arrester a specified number of times without causing damage to it.

**Duty Cycle Voltage:** The designated maximum permissible voltage between its terminals at which an arrester is designed to perform its duty cycle.

**ESP Polymer:** Proprietary ESP™ weathershed material, made of a silicone/EPDM alloy. ESP's properties have been confirmed in a series of performance tests that include tracking resistance, contamination, aging, and seal design.

**Fault Current:** The current from the connected power system that flows in a short circuit.

**Front of Wave Impulse Sparkover Voltage:** The impulse sparkover voltage with a wave front that rises at a uniform rate and causes sparkover on the wave front.

**Grading Ring:** A metal ring mounted to electrostatically modify the voltage gradient or distribution. This will come with the arrester if required by the design.

**Ground Terminal:** The conducting part provided for connecting the arrester to ground.

**Impulse Protective Level:** The discharge-voltage value for a defined wave shape.

**Impulse Withstand Voltage:** The crest value of an impulse that, under specified conditions, can be applied without causing a disruptive discharge.

**Line Terminal:** The conducting part of an arrester provided for connecting the arrester to the circuit conductor.



# Engineering Terminology

**Maximum Design Cantilever Load-Static (MDCL-Static):** The maximum cantilever load the surge arrester is designed to continuously carry.

**MOV (Metal Oxide Varistor):** The power semi-conductor that limits the surge voltage allowing the arrester to perform its protection function. This is the electrically active component of the surge arrester.

**MCOV (Maximum Continuous Operating Voltage):** The maximum designated root-mean-square (rms) value of power-frequency voltage that may be applied continuously between the terminals of the arrester.

**Partial Discharge (PD):** A localized electric discharge resulting from ionization in an insulation system when the voltage stress exceeds critical value. The discharge partially bridges the insulation between electrodes.

**Reference Current (Iref):** The peak value of the resistive component of a power frequency current high enough to make the effects of stray capacitance of the arrester negligible.

**Reference Voltage (Vref):** The lowest peak value independent of polarity of power frequency voltage, divided by the square root of 2, required to produce a resistive component of current equal to the reference current of the arrester.

**Routine Tests:** Tests made by the manufacturer on every device to verify that the product meets the design specifications.

**Surge Arrester:** A protective device for limiting surge voltages on equipment by diverting surge current and returning the device to its original status. It is capable of repeating these functions multiple times.

**TOV (Temporary Over Voltage):** A power frequency voltage in excess of normal line-to-ground voltage. A TOV is typically system generated. The magnitude and duration are a function of the power system parameters.

**Prior Duty TOV:** The TOV of the arrester if it has been energized before an over voltage event.

**No Prior Duty TOV:** The TOV of the arrester if it has not been energized prior to an over voltage event.

dependability

# Arrester Routine Factory Testing

**Arrester Routine Factory Testing:** After assembly, the arresters are 100 percent tested as follows:

**Discharge Voltage:** Determined by the sum of the resistor elements, each arrester is tested to be within a manufacturer specified range that aligns with the arrester’s published ratings.

**Reference Voltage:** The voltage at which the arrester conducts the reference current per the table below. This test verifies the proper MOV discs were used in the assembly.

PVI-LP	7 mA
EVP	9.5 mA
VL	11 mA
MVN ,SVN, SVNH	17 mA
SVNX	34mA

**Partial Discharge (PD):** Power-frequency voltage is raised to the duty cycle voltage rating of the arrester or unit, held for not less than 2s, and then lowered to 1.05 times the MCOV of the arrester or unit. The measured PD shall not exceed 10 pC.

**Seal Test:** The helium-mass spectrometer test is performed on arresters with >10% internal gas volume to verify the environmental seal of the arrester or unit.

**Power Frequency (PF):** A minimum voltage of 1.20 times the MCOV of the arrester or unit is applied to verify that the measured values of watts loss does not exceed the arrester or unit’s specified limits.

The above testing procedure indicates our diligence in producing high quality metal-oxide arresters.

## Flash Fact:

*Surge arresters can withstand many surge events over their lifetime.*



# Seismic Testing

IEEE 693 is the governing standard for seismic testing of substation equipment for IEEE C62.11 and IEC 60099-4 surge arresters. The IEEE 693 standard details test procedures for seismically validating a wide range of products including arresters, switches, bushings, and a multitude of other equipment. Hubbell Power Systems qualifies the seismic capability of its surge arresters to Annex K of IEEE 693.

All VL and PVI-LP arresters under 35 kV rated voltage are seismically qualified by inherently acceptable criteria. All other Hubbell Power Systems arresters are qualified by shake table testing. To be qualified, a surge arrester must survive the shake table test with no structural damage and remain functional, as demonstrated by successfully passing routine production tests after shake table testing.

IEEE 693 allows seismic qualification based on the concept of “qualifying equipment by group”. This concept permits products of different voltage ratings, but similar physical structure, to be combined into groups for qualification purposes, with the most seismically vulnerable piece of equipment of each group being analyzed or tested. The qualification level for Hubbell Power Systems arresters is summarized below. All arresters which do not exceed the listed height, mass and center of gravity for these arresters is also qualified to IEEE 693.

Seismic Capability					
Product Line	MCOV Certified (kV)	ZPA * Level (g)	Height (in)	Center of Gravity (in)	Mass (lbs)
EVP	115	1.25	61	31.8	82.1
SVN	353	0.5	165	88.2	596.0
SVNH	318	1.0	152	80.8	829.0
SVNX	318	1.25	152	79.3	1080.0
MVN	335	1.0	160	80.5	898.0

\* Zero period acceleration (ZPA): The acceleration level of the high-frequency, non-amplified portion of the response spectrum (e.g., above the cutoff frequency, 33 Hz). This acceleration corresponds to the maximum (peak) acceleration of the time history used to derive the spectrum.

Hubbell Power Systems maintains certification test reports for every seismically certified product. Please contact your Hubbell Power Systems representative at 573.682.5521 for a copy of the certification reports.







**Notes**



service

NOTE: Because Hubbell has a policy of continuous product improvement, we reserve the right to change design and specifications without notice.

©Copyright 2016 Hubbell Incorporated

**OHIO BRASS**

*Never Compromise*™  
[www.hubbellpowersystems.com](http://www.hubbellpowersystems.com)

